

INNOVA[®]

7111

SDS

SMART DIAGNOSTIC SYSTEM

OE-Level Diagnostic Tablet



POWERED BY



HELLO...

On behalf of everyone at INNOVA, we want to welcome you and thank you for purchasing the **INNOVA® 7111 Smart Diagnostic System (SDS)** tablet! Our tablet includes tons of pro-level features designed to help maximize your OBD II diagnostic routine. In this manual, we will guide you on how to access a comprehensive library of time-saving diagnostic and service tools including:

- ✓ *Check Engine Light Diagnostics*
- ✓ *Bi-Directional Active Tests*
- ✓ *Special Functions*
- ✓ *44+ Workshop Tools services*
- ✓ *Enhanced Data Stream*
- ✓ *TPMS / Tire Pressure Readings*
- ✓ *Transmission Temperature Readings*
- ✓ *Hybrid Battery Cell Voltage Readings*
- ✓ *EPB / ABS Servicing*
- ✓ *Full OEM Network Scans*
- ✓ *Battery Reset*
- ✓ *Digital Multimeter*
- ✓ *Oil Maintenance Reset*
- ✓ *SRS / Safety System Inspection*
- ✓ *10 OBD II Modes*
- ✓ *Oil Life, Oil Level Checks, Brake Pad Life, Transmission Temperature, Engine Coolant Level*
- ✓ *Battery System Check*
- ✓ *Stream Live Data PIDs*
- ✓ *Smog / Emissions Readiness*
- ✓ *ABS Inspections*
- ✓ *And Much More...*

Plus, gain the benefit of having unlimited access to real world solutions:

POWERED BY



RepairSolutionsPRO™ increases the power of your INNOVA OBD II diagnostic tablet by delivering the most complete automotive repair database with verified fixes from ASE Certified Master Technicians. Get the right fix and the right parts instantly right on your SDS Scan Tool Tablet.

Enjoy using your INNOVA SDS Scan Tool Tablet!

Yours sincerely,

The Innova Technical Team

P.S.: See what's new, connect with us on social...





TABLE OF CONTENTS

LEGAL INFORMATION	1
FCC Compliance Statement	1
Trademarks	1
Patents	2
Version Information	2
California Product Warnings	2
SAFETY PRECAUTIONS	3
Safety First!	3
Safety Alert Icons	4
GLOSSARY	5
OBD II Terminology	5
OBD II Monitors	6
Continuous Monitors	6
Non-Continuous Monitors	6
Additional Terminology & Acronyms	7
INTRODUCTION	9
Tablet Controls	9
Power ON and Power OFF	9
Operating Modes	10
Initial Tablet Setup	11
The Home Screen	11
Technical Specifications	13
RepairSolutionsPRO® (RSPRO®)	13
RSPRO® Offers	13
GETTING STARTED	15
Connecting The Tablet	15



AutoLink Connection15

Scanning a Vehicle16

OBD II DIAGNOSTICS 17

 Performing a Scan - OBD II Diagnostics.....17

 Viewing Scan Results – OBD II Diagnostics18

 Emissions Readiness – Interpreting Results 18

 Confirmed/MIL DTC 19

 Repair Info Powered By MOTOR 19

 Fix for DTC (RSPRO®) 22

 Monitor Status. 24

 Confirmed DTC 25

 Pending DTC. 25

 Permanent DTC 25

 Additional Testing Utilities..... 26

 Erase DTCs - Mode \$04 26

 Live Data - Mode \$01 27

 OBD Testing Modes 30

 Vehicle Enhance Information - Mode \$09 34

 Vehicle Info 36

 Editing Customer Information 38

 TSBs and Recalls 38

 Scheduled Maintenance. 39

 Predicted Failures. 39

OEM DIAGNOSTICS 40

 Performing a Scan – OEM Diagnostics 40

 Select System & Scan All Systems41

 Scanning the Select System & Scan All Systems 41

Viewing the Test Results	42
Erase All OEM DTCs	43
Rescan All Systems	44
Viewing & Scanning An Individual Control Module	44
Reading DTCs for a Selected Module	45
Erasing DTCs for a Selected Module	46
Viewing Live Data for a Selected Module	46
Performing Active Tests for a Selected Module	48
Performing Special Functions for a Selected Module	48
Viewing ECU Information for a Selected Module	49
Vehicle Inspection Health Report	50
For Diagnostic Report, Customer Report, and Collision Industry Report	51
For Digital Vehicle Report	54
System Voltages	54
Custom Scan	55
FCA & Nissan Secure Gateway Access	57
What is SGW?	57
Functions Limited by SGW	57
Preparing the Tablet for SGW Access	57
Unlocking the SGW	58
WORKSHOP TOOLS	59
Available Functions	59
Resets	61
Oil Maintenance Reset	61
Battery Reset	61
Electronic Parking Brake (EPB) Reset	62
Maintenance Reset	63
Transmission Reset	64



Transmission Fluid Change Reset	65
DPF Reset	66
Reset Electric Traction System.	67
Immobilizer Reset.	68
Read/Write Odometer Settings	69
Language Change Reset	70
NOx Sensor Reset	70
Cylinder Reset.	71
Adblue Reset	72
HV Battery Reset	73
Rain/Light Sensor Reset	74
EGR Reset	75
Electronic Water Pump Start Reset.	76
Tire Size Reset	77
Stop/Start Reset	78
Relearns	79
TPMS Relearn	79
Throttle Body Relearn/TEC Learn.	80
AC System Relearn	81
Clutch Relearn.	82
Routines	83
ABS Bleeding	83
Battery/Alternator Test	83
EV/HEV/PHEV Battery Health	85
Transmission Fluid Temperature	88
Transmission Fluid Level Check	88
Injector Coding	89
Window Door Roof	90
Key Coding Procedure	91

A/F Setting	91
Transport Mode	92
Coolant Bleeding	93
Limit Speed	94
Oxygen Sensor Test	95
Power Balance	96
Calibrations	97
Steering Angle Sensor (SAS) Calibration	97
Suspension Calibration	98
Headlamp Calibration	99
Occupant Seat Sensor Calibration	100
Configurations	101
VIN Read/Write	101
ECU Coding	102
Favorites Functions	103
PREVIOUS VEHICLES	104
Scan History Reports	104
Delete the History Reports	104
Viewing Scan History Reports	105
Emailing & Printing Reports	105
Playback Recorded Live Data	106
SETTINGS	108
Technical Support (Send an Email)	108
Date and Time Settings	109
Vehicle Inspection Setup	110
RSPRO Settings	111
MOTOR Plan Information	112

Wi-Fi Settings	112
Smog Check or I/M Program Location	113
Regional Settings	114
Language	114
Idle Time Settings	114
Auto Shut Off	115
Volume Settings	115
Brightness Settings	116
Theme Settings	116
RSPRO Account Information	116
Create an Account	116
Edit Account Information	117
Account Log In	117
Reset Account Password	117
Version Information	117
Report an Issue	118
Factory Reset	119
SUPPORT	120
Tool Library	120
Smog Check or I/M Program LED Definition	121
Icon Monitor Status	121
DTC Library	121
DLC Locator	122
Using the DLC Locator	122
Common DLC Locations	123
View User's Manual	124
Tutorials	124
7111 Introduction	124

First Time User Experience	125
Repair Info Powered By Motor	126
OBD II Diagnostics.	126
OEM Diagnostics.	127
Workshop Tools	128
Settings	128
Previous Vehicles/Scan History	129
Technical Support	130
Demo Mode	131
DIGITAL MULTIMETER	133
Introduction	133
Live Data Split Screen Mode	135
DMM Settings	136
TROUBLESHOOTING & FAQ	137
Troubleshooting	137
FAQ	139
WARRANTY & CUSTOMER SERVICE.	140
Limited Warranty.	140
Customer Service	140

LEGAL INFORMATION

FCC COMPLIANCE STATEMENT

This equipment has been tested and found to comply with the limits for a Class B digital device, pursuant to part 15 of the FCC Rules. These limits are designed to provide reasonable protection against harmful interference in a residential installation. This equipment generates, uses and can radiate radio frequency energy and, if not installed and used in accordance with the instructions, may cause harmful interference to radio communications. However, there is no guarantee that interference will not occur in a particular installation. If this equipment does cause harmful interference to radio or television reception, which can be determined by turning the equipment off and on, the user is encouraged to try to correct the interference by one or more of the following measures:

- Reorient or relocate the receiving antenna.
- Increase the separation between the equipment and receiver.
- Connect the equipment into an outlet on a circuit different from that to which the receiver is connected.
- Consult the dealer or an experienced radio/TV technician for help.

Changes or modifications not expressly approved by the party responsible for compliance could void the user's authority to operate the equipment.

FCC RF Radiation Exposure Statement

- The transmitters within this device must not be co-located or operating in conjunction with any other antenna or transmitter.
- This equipment complies with IC radiation exposure limits set forth for an uncontrolled environment. End users must follow the specific operating instructions for satisfy RF exposure compliance. Please follow the operation instructions as documented in this manual to fulfill IC RF exposure compliance requirements.

TRADEMARKS

Title, ownership rights, and intellectual property rights in the Products and Services shall remain in Innova and/or its licensors and other suppliers. Licensee and End Users acknowledge such ownership, confidential information, and intellectual property rights and will not take any action to jeopardize, limit or interfere in any manner with Innova's or its licensors' or other suppliers' ownership of or rights with respect to the Products and Services. The Products and Services may be protected by Patent, Trademark, Copyright and/or other intellectual property laws and by international treaties. All trademarks used in connection with the Products and Services are owned by Innova, its affiliates or its licensors and other suppliers, and no license to use any such trademarks is provided hereunder. Licensee and End Users agree that Innova may use in any manner and without limitation all comments, suggestions, complaints and other feedback Licensee and End Users provide relating to the Products and Services. For more information and current listing of trademarks, please visit <https://www.innova.com/pages/trademarks>.

PATENTS

Innova Electronics Corp. protects its intellectual property with numerous U.S. patents, which were used to research, design and manufacture this product. Please visit <https://www.innova.com/pages/patents> for additional information.

VERSION INFORMATION

Please note that the images and functions in this manual may differ based on the current **Firmware Version (FW)** and **Software Version** you have. To check your tablet's current version and to check for updates, please refer to the **SETTINGS** tab under the **Version Information** section. [[See page 117](#)]

CALIFORNIA PRODUCT WARNINGS

 WARNING

This product can expose you to chemicals including DiNP, which is known to the State of California to cause cancer. For more information go to www.P65Warnings.ca.gov.

SAFETY PRECAUTIONS

SAFETY FIRST!

It is important that every user of this product read all instructions and warnings included in this manual to ensure their safety, the safety of others, and to prevent damage to this product and the vehicle being diagnosed and repaired. This manual describes common test procedures used by experienced service technicians. It is assumed that the user has a good understanding of vehicle systems before using this product.

Many test procedures require precautions to avoid accidents that can result in personal injury, and/or damage to the vehicle or test equipment. At a minimum, the following safety standards should be followed whenever using this product, or whenever working on a vehicle.

- ❑ When an engine is running, it produces carbon monoxide, a toxic and poisonous gas. To prevent serious injury or death from carbon monoxide poisoning, **operate the vehicle ONLY in a well-ventilated area.**
- ❑ To protect your eyes from propelled objects as well as hot or caustic liquids, **always wear approved safety eye protection.**
- ❑ When an engine is running, many parts (such as the coolant fan, pulleys, fan belt, etc.) turn at high speed. To avoid serious injury, **always be aware of moving parts.** Keep a safe distance from these parts as well as other potentially moving objects.
- ❑ Engine parts become very hot when the engine is running. To prevent severe burns, **avoid contact with hot engine parts.**
- ❑ Before starting an engine for testing or troubleshooting, make sure the parking brake is engaged. **Put the transmission in park** (for automatic transmission) **or neutral** (for manual transmission). **Block the drive wheels** with suitable tire blocks.
- ❑ Connecting or disconnecting test equipment when the ignition is ON can damage test equipment and the vehicle's electronic components. **Turn the ignition OFF before connecting the tablet to or disconnecting the tablet from the vehicle's Data Link Connector (DLC).**
- ❑ To **prevent damage to the on-board computer** when taking vehicle electrical measurements, always use a digital multimeter with at least 10 Megohms of impedance.
- ❑ Fuel and battery vapors are highly flammable. To prevent an explosion, keep all sparks, heated items, and open flames away from the battery and fuel vapors. **DO NOT SMOKE NEAR THE VEHICLE DURING TESTING.**
- ❑ **Don't wear loose clothing or jewelry when working on an engine.** Loose clothing can become caught in the fan, pulleys, belts, etc. Jewelry is highly conductive and can cause a severe burn if it makes contact between a power source and ground.

SAFETY ALERT ICONS

As you read this manual, color-coded icons are used throughout to identify safety alerts and warnings. These are provided to help prevent serious injury to you, injury to bystanders, and damage to property or equipment. The meanings of these icons are as follows:



Yellow Icon – Indicates a **“NOTE:”** statement that offers special information or tips on what is being instructed.



Orange Icon – Identifies a potential hazardous situation. Provides a **“WARNING:”** statement on how to proceed to avoid serious injury to the user or bystanders, and/or damage to equipment.



Red Icon – Identifies an imminent hazardous situation. Provides an immediate **“DANGER:”** alert on what must be done to prevent serious injury or death to the user or bystanders.

GLOSSARY

OBD II TERMINOLOGY

The following terms and their definitions are related to OBD II systems.

- **Powertrain Control Module (PCM)** - The PCM is the OBD II accepted term for the vehicle's "on-board computer." In addition to controlling the engine management and emissions systems, the PCM also participates in controlling powertrain (transmission) operation. Most PCMs also have the ability to communicate with other computers on the vehicle (ABS, ride control, body, etc.).
- **Monitor** - Monitors are "diagnostic routines" programmed into the PCM. The PCM utilizes these programs to run diagnostic tests, and to monitor operation of the vehicle's emissions-related components or systems to ensure they are operating correctly and within the vehicle manufacturer's specifications. Currently, up to fifteen Monitors are used in OBD II systems. Additional Monitors will be added as the OBD II system is further developed.



NOTE: *Not all vehicles support all fifteen Monitors.*

- **Enabling Criteria** - Each Monitor is designed to test and monitor the operation of a specific part of the vehicle's emissions system (EGR system, oxygen sensor, catalytic converter, etc.). A specific set of "conditions" or "driving procedures" must be met before the computer can command a Monitor to run tests on its related system. These "conditions" are known as "**Enabling Criteria**." The requirements and procedures vary for each Monitor. Some Monitors only require the ignition key to be turned "**On**" for them to run and complete their diagnostic testing. Others may require a set of complex procedures, such as starting the vehicle when cold, bringing it to operating temperature, and driving the vehicle under specific conditions before the Monitor can run and complete its diagnostic testing.
- **Complete/Incomplete** - The terms "**Complete**" and "**Incomplete**" are used throughout this manual. "**Complete**," means the PCM **has** commanded a particular Monitor to perform the required diagnostic testing on a system to ensure the system is operating correctly (within factory specifications). The term "**Incomplete**" means the PCM **has not** yet commanded a particular Monitor to perform diagnostic testing on its associated part of the emissions system.
- **Trip** - A Trip for a particular Monitor requires that the vehicle is being driven in such a way that all the required "Enabling Criteria" for the Monitor to run and complete its diagnostic testing are met. The "Trip Drive Cycle" for a particular Monitor begins when the ignition key is turned "**On**." It is successfully completed when all the "Enabling Criteria" for the Monitor to run and complete its diagnostic testing are met by the time the ignition key is turned "**Off**." Since each of the fifteen Monitors is designed to run diagnostics and testing on a different part of the engine or emissions system, the "Trip Drive Cycle" needed for each individual Monitor to run and complete varies.
- **OBD II Drive Cycle** - An OBD II Drive Cycle is an extended set of driving procedures that takes into consideration the various types of driving conditions encountered in real life. These conditions may include starting the vehicle when it is cold, driving the vehicle at a steady speed (cruising), accelerating, etc. An OBD II Drive Cycle begins when the ignition key is turned "**On**" (when cold) and ends when the vehicle has been driven in such a way as to have all the "Enabling Criteria" met for all its applicable Monitors. Only those trips that provide the Enabling Criteria for all Monitors applicable to the vehicle to

run and complete their individual diagnostic tests qualify as an OBD II Drive Cycle. OBD II Drive Cycle requirements vary from one model of vehicle to another. Vehicle manufacturers set these procedures. Consult the vehicle's service manual for OBD II Drive Cycle procedures.



NOTE: Do not confuse a "Trip" Drive Cycle with an OBD II Drive Cycle. A "Trip" Drive Cycle provides the "Enabling Criteria" for one specific Monitor to run and complete its diagnostic testing. An OBD II Drive Cycle must meet the "Enabling Criteria" for all Monitors on a particular vehicle to run and complete their diagnostic testing.

- **Warm-up Cycle** - Vehicle operation after an engine off period where engine temperature rises at least 40°F (22°C) from its temperature before starting, and reaches at least 160°F (70°C). The PCM uses warm-up cycles as a counter to automatically erase a specific code and related data from its memory. When no faults related to the original problem are detected within a specified number of warm-up cycles, the code is erased automatically.

OBD II MONITORS

To ensure the correct operation of the various emissions-related components and systems, a diagnostic program was developed and installed in the vehicle's on-board computer. The program has several procedures and diagnostic strategies. Each procedure or diagnostic strategy is made to monitor the operation of, and run diagnostic tests on, a specific emissions-related component or system. These tests ensure the system is running correctly and is within the manufacturer's specifications. On OBD II systems, these procedures and diagnostic strategies are called "Monitors."

Currently, fifteen Monitors are supported by OBD II systems. Additional Monitors may be added because of Government regulations as the OBD II system grows and matures. Not all vehicles support all fifteen Monitors. Additionally, some Monitors are supported by "Spark Ignition" vehicles only, while others are supported by "Compression Ignition" vehicles only.

Monitor operation is either "**Continuous**" or "**Non-Continuous**," depending on the specific Monitor.

CONTINUOUS MONITORS

Three of these Monitors are designed to constantly monitor their associated components and/or systems for proper operation. Continuous Monitors run constantly when the engine is running.

CCM = Comprehensive Component Monitor (CCM)

MIS = Misfire Monitor

FUE = Fuel System Monitor

NON-CONTINUOUS MONITORS

The other twelve Monitors are "non-continuous" Monitors. "Non-continuous" Monitors perform and complete their testing once per trip.

O2S = Oxygen Sensor Monitor

HTR = Oxygen Sensor Heater Monitor

CAT = Catalyst Monitor

HCA = Heated Catalyst Monitor

EGR = EGR (Exhaust Gas Recirculation) System Monitor

EVA = EVAP System Monitor

AIR = Secondary Air System Monitor



NOTE: The following Monitors became standard beginning in 2010. The majority of vehicles produced before this time will not support these Monitors.

HCC = NMHC (Non-Methane Hydrocarbon Converting) Catalyst Monitor

NOx = NOx Adsorber Monitor

BPS = Boost Pressure System Monitor

EGS = Exhaust Gas Sensor Monitor

DPF = PM (Particulate Matter) Filter Monitor

ADDITIONAL TERMINOLOGY & ACRONYMS

- **ABS** = Anti-Lock Braking System
 - **Cal ID** = Vehicle's calibration ID
 - **CVN** = Calibration Verification Number
 - **DLC** = Data Link Connector (vehicle's data port)
 - **DTC** = Diagnostic Trouble Code
 - **I/M** = INSPECTION and MAINTENANCE
 - **KOEO** = Key On, Engine Off
 - **KOER** = Key On, Engine Running
 - **MIL** = Malfunction Indicator Light (Check Engine Light)
 - **OBD** = On-Board Diagnostics
-

- **OBD II** = On-Board Diagnostics, Second Generation
- **OEM** = Original Equipment Manufacturer
- **ODO** = Odometer
- **PID** = Parameter Identification Data
- **SDC** = Since DTCs Cleared
- **SRS** = Supplemental Restraint System
- **TDC** = This Driving Cycle
- **TPMS** = Tire Pressure Monitoring System
- **TSBs** = Technical Service Bulletins
- **VIN** = Vehicle Identification Number

INTRODUCTION

TABLET CONTROLS

See **Figure 1** for the locations of items 1 through 9, below.

1. **POWER Button** – Turns the tablet “On” and “Off.”
2. **USB Charging Port** – Charge the tablet through a USB port.
3. **TF-Card Port** – Supports installation of a TF (expandable memory) card. Functionality is currently disabled.
4. **Mini HDMI Port** – Supports connection of an external HDMI (High-Definition Multimedia Interface) compatible external display.
5. **Headphone Port** – Supports connection of external headphones. (Future expansion)
6. **Display** – Shows information on a 7-inch color LCD.
7. **DLC Cable** – Connects the tablet to the vehicle’s on-board Data Link Connector (DLC).
8. **Rear Kickstand** – Holds the tablet upright.
9. **Detachable VCI Connector** – The detachable Vehicle Communication Interface (VCI) connector allows mobility and flexibility around the vehicle by detaching the tablet from the DLC cable and wirelessly connecting via Bluetooth®. [[See page 10](#)]

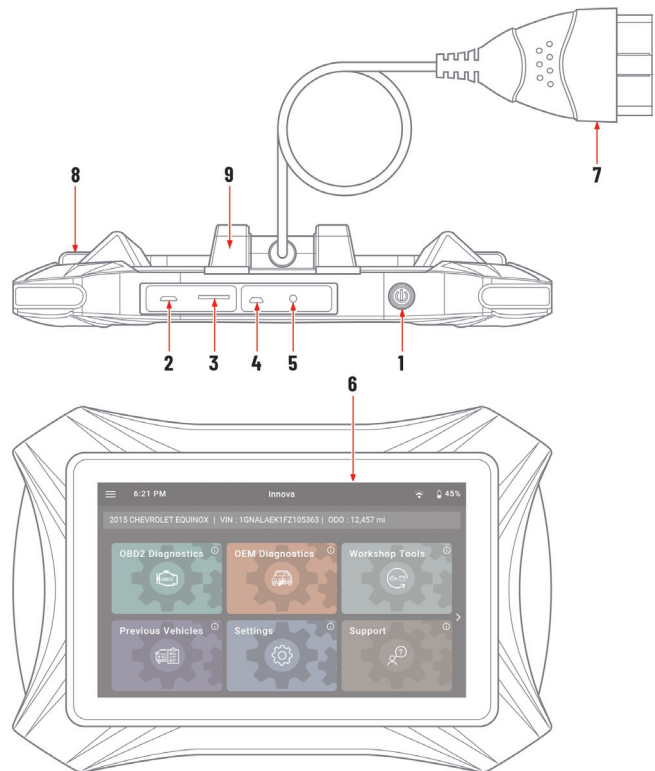

Figure 1: Tablet Controls



POWER ON AND POWER OFF

To power ON the tablet:

1. With the tablet off, press and hold the **POWER** button for approximately 3 seconds, then release.
 - The screen displays the message “LOADING” while the software loads.
 - When the software has been loaded, the Home screen displays. [[See page 11](#)]
2. If the tablet is connected to a vehicle, the message “Retrieving vehicle information...” automatically displays while the tablet establishes communication with the vehicle.

To restart or power OFF the tablet:

1. With the tablet on, press and hold the **POWER** button for approximately 3 seconds.

- The “power down” options menu displays at the right side of the screen.
2. To restart the tablet:
 - Tap the  **Restart** icon.
 - The screen displays the message “LOADING” while the software loads.
 - The Home screen displays once the software is loaded. [\[See page 11\]](#)
 - If the tablet is connected to a vehicle, the message “*Retrieving vehicle information...*” displays while the tablet establishes communication with the vehicle.
 3. To power off the tablet:
 - Tap the  **POWER** icon.
 - The tablet powers down and turns off.

OPERATING MODES

The tablet supports two operating modes for connecting the Vehicle Communication Interface (VCI):

1. USB Mode

- In this mode, the VCI connector is attached directly to the back of the tablet using the built-in pogo pin interface.
- This provides a stable, wired data link.
- **How to use USB Mode:**
 - Power on the tablet.
 - Attach the VCI connector firmly to the back of the tablet (align with pogo pins).
 - Connect the DLC cable to the vehicle’s Data Link Connector (DLC). [\[See page 15\]](#)



2. BLE Mode

- In this mode, the VCI connector is detached from the tablet and remains connected to the vehicle via the DLC cable.
- The tablet communicates with the VCI wirelessly via Bluetooth, allowing flexibility and mobility around the vehicle.
- **How to use BLE Mode:**
 - Power on the tablet.
 - Detach the VCI connector from the tablet.
 - Connect the VCI to the vehicle’s DLC using the DLC cable. [\[See page 15\]](#)
 - The tablet automatically connects with the VCI.



NOTE: Once the VCI is successfully connected to the tablet, the top three Home screen icons (OB2 II Diagnostics, OEM Diagnostics, and Workshop Tools) are activated.

INITIAL TABLET SETUP

Follow these steps to setup the tablet for the first time.

1. **Charge Tool** – use the included charging cable to completely charge your tablet before conducting your first scan.
2. **Power On** – Once fully charged, press and hold the  **POWER** button for approximately 3 seconds.
3. **Setting your tablet preferences** – Configuring the Wi-Fi Connection, Time zone, Preferred Units, Language, Idle Time, Volume Level, Brightness Level and Theme Preference. [[See page 108](#)]
4. **Check for Updates** – We're continuously making free software, data, and firmware updates. It is important to keep your tablet up to date to ensure its best performance.
 - Follow the on-screen instructions to check for updates and automatically update your tablet.



NOTE: To proceed, your tablet must be linked to a Wi-Fi network.

5. **Create Your Account** – Allows complete access to all of the tablet's powerful features.
 - Fill out the **Account Info** form by entering your name, email address, desired password, and other required personal details.
 - Select the **Business Info** form and provide your business name, phone number, address, and additional business information.
6. **First-Time User Experience Tutorial** – The tablet displays a screen with detailed tutorials, guiding users on how to use its various features and functions. [[See page 125](#)]
 - For an overview and detailed insight into each function, swipe sideways to view each step of the tutorial.
 - Tap the **Skip** button if you want to skip this tutorial.
7. **Smog Check or I/M Program Location** – Allows you to select your U.S. state to enhance emission readiness logic.
 - Enter your U.S. state, then tap **Continue** to finish the Initial Tablet Setup.
8. **Enjoy your INNOVA® Smart Diagnostic System!**

Have questions? We're here to help:

- **Email Us:** customercare@innova.com
- **Call Us:** 800-544-4124 (Monday through Friday, 6am - 6pm PST)

THE HOME SCREEN

The Home screen provides access to all the tablet's primary functions. See **Figure 2** for the explanation of items 1 through 13, below.

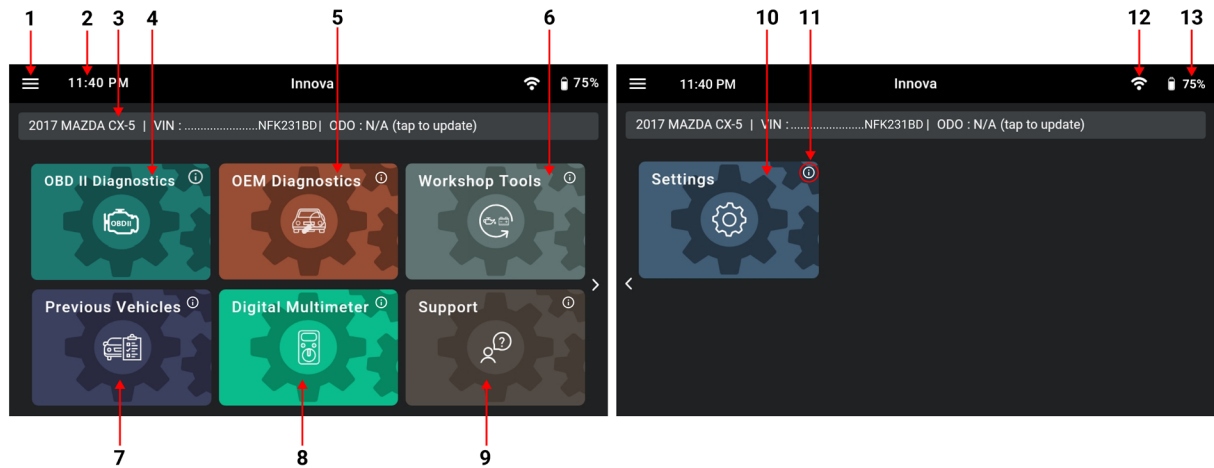

Figure 2: The Home Screen

1. **☰ Main Menu** – Quick access to Home, Previous Vehicles, Support, Settings and Updates (when available).
2. **Clock** – Displays the current time.
3. **Vehicle Info Bar** – When connected to a vehicle, dialog displays vehicle's year, make, model, VIN, and current mileage (ODO).
4. **OBD II Diagnostics Tab** – Professional-level functionality for reading and clearing OBD II powertrain emission-related fault codes; viewing Freeze Frame and I/M data; monitoring, graphing, recording and playback of Live Data, vehicle information, and performs emission readiness testing. [\[See page 17\]](#)
5. **OEM Diagnostics Tab** – Professional-level functionality for reading and clearing fault codes; monitoring, graphing, recording and playback of Live Data; performs bi-directional controls, routines, relearns and calibrations for vehicle on-board systems. [\[See page 40\]](#)
6. **Workshop Tools Tab** – Quick and easy access to the most popular routines, self-tests and calibrations used for service and repairs. [\[See page 59\]](#)
7. **Previous Vehicles Tab** – Access and view reports for all previously tested vehicles, including pre-recorded Live Data streams. [\[See page 104\]](#)
8. **Digital Multimeter** – Access Digital Multimeter functionality for measuring voltage, current, and resistance. The compatible device is the DS200 which is connected to the tablet via Bluetooth. [\[See page 133\]](#)
9. **Support Tab** – Access the Tool Library, Smog Check or I/M Program LED Definition and Icon Monitor Status, DLC Locator, User Manual, Demo Mode, and Tutorials. Get connected with Innova's ASE Certified Technical Team for additional support. [\[See page 120\]](#)
10. **Settings Tab** – Access your tablet's settings, including Wi-Fi, software updates, and other tablet settings. [\[See page 108\]](#)
11. **i Icon Description** - Tap to view the description for each item in the Home screen.
12. **Wi-Fi Icon** - Tap to access and edit the tablet's Wi-Fi settings. [\[See page 112\]](#)
13. **75%** - Displays the current tablet battery status.

TECHNICAL SPECIFICATIONS

The following table provides the tablet's current technical specifications*:

Display Type	7" Touch Panel/1280x720 pixels
J1962 DLC Cable	6-foot Detachable 16-pin OBD II Compliant Connector
Detachable Vehicle Communication Interface (VCI) with Bluetooth® Connectivity	Maximum communication range of 30 feet
Wi-Fi	802.11b/g/n
Operating Temperature	23°F to 113°F (-5°C to 45°C)
Memory	2GB RAM / 32GB ROM
Tablet Case	Rugged ABS Shock & Drop Resistant
Included Accessories	Molded Storage Case, Quick Start Guide, USB Charger

*Manufacturer reserves the right to change technical specifications at any time.

RepairSolutionsPRO® (RSPRO®)

Innova's **RepairSolutionsPRO® (RSPRO®)** is embedded into your Scan Tool Tablet and offers a free web-based service created to assist professional technicians simplify and augment their vehicle diagnostic process.

In essence, it helps you decode the diagnostic data collected by your INNOVA® OBD II Scan Tool Tablet to arrive at a most likely fix. At its core, it links to a database of millions of real-world verified fixes—collected over the last 25 years by ASE Master Technicians across the U.S.—that is cross-referenced to your specific vehicle's problem to instantly arrive at a verified fix. Think of it as a second opinion from your most trusted peers to help you diagnose and repair more vehicles.

POWERED BY



RSPRO® OFFERS...

- **Verified Fixes** – Provides the most likely fix(es) with recommended parts to repair the problem. These fixes are reported and verified by ASE Technicians for the specific vehicle's retrieved DTCs. [[See page 22](#)]

- **TSBs & Recalls** – Learn if there are any special NHTSA safety recalls or Technical Service Bulletins (TSBs) issued by the tested vehicle’s manufacturer. [[See page 38](#)]
- **Scheduled Maintenance** – Offers the vehicle manufacturer’s recommended maintenance intervals, which can be used to guide your customer on scheduled service routines. Plus, conveniently order the correct maintenance part(s) right from the tablet. [[See page 39](#)]
- **Predicted Failures** – With millions of verified repair solutions, get a statistical probability of what failures may occur within the next 12 months. Use this to guide your customer on potential issues to look out for. [[See page 39](#)]
- For additional resources and content, visit us at <https://pro.repairsolutions.com>.

GETTING STARTED

CONNECTING THE TABLET

1. Turn the vehicle's ignition OFF.
2. Locate the vehicle's 16-pin Data Link Connector (DLC). [[See page 122](#)]



NOTE: Some DLCs have a plastic cover that must be removed before connecting the tablet.

3. Connect the tablet to the vehicle's DLC. The cable connector is keyed and will only fit one way.
 - If you have problems connecting the cable to the DLC, rotate the connector 180°.
 - If you still have problems, check the DLC on the vehicle and on the tablet.

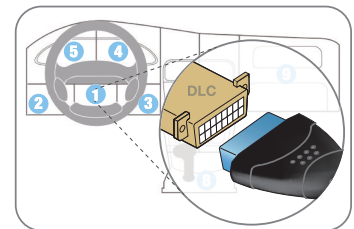

AUTOLINK CONNECTION

The tablet features an “**AutoLink Connection**” function, which automatically retrieves vehicle information upon plugging the tablet into the vehicle's Data Link Connector (DLC) port.

Using the AutoLink Function

1. Verify that the tablet is connected as indicated above (*Connecting The Tablet*).
2. If the tablet is off, power ON the tablet by pushing the **POWER** button for 3 seconds.
3. Turn the ignition ON. **DO NOT** start the engine.
 - Tablet begins communicating and displays “*Retrieving Vehicle Information...*”.
 - If an “information” dialog displays, follow the on-screen instructions to establish a connection.
4. Once complete, the tablet displays the vehicle's Year, Make, Model, VIN, and mileage on the Vehicle Info Tab.



NOTE: With certain vehicles, you may be required to manually input some of the vehicle's information. This may include the vehicle's Year, Make, Model, Trim, Body Code, Engine, vehicle's VIN, and/or the vehicle's mileage.

Providing Vehicle's VIN Information

1. A dialog appears requesting a Vehicle Identification Number (VIN).
2. Tap the dialog window and enter the vehicle's 17-digit VIN number.
 - The **Submit** button becomes “active” once all 17-digits are entered.
3. Tap the **Submit** button.
 - An error dialog will display if the VIN is unable to be decoded. Re-enter the VIN.
 - If the tablet is still unable to decode the VIN, tap **Select Vehicle** (*see steps below*).

Providing Vehicle Selection Information

1. A dialog displays requesting **Vehicle Selection**.
2. Tap each of the available entries (**Year, Make, Model, Trim, Body Code, Engine**).
 - A grayed-out selection means that an entry is not available or not necessary for this vehicle.
3. Make a selection under each option.
4. Tap **Continue** to save your selections and return to the Home screen.
5. Tap **Cancel** to exit without selecting and return to the Home screen.

Providing Vehicle's Mileage

2009 DODGE SPRINTER 2500 | VIN : WD0PE745295375510 | ODO : 7,990 mi

1. If the vehicle doesn't support automatic retrieval of stored mileage, a dialog is displayed on the screen.
2. Input the vehicle's odometer reading:
 - Tap the entry box and enter the mileage.
 - Tap **Submit** to confirm entry and return to the Home screen.
3. If you choose to cancel, the mileage will be marked as missing, and the Vehicle Info Bar will display "*ODO: N/A (tap to update)*".
 - Tap the Vehicle Info Bar "(tap to update)" to re-enter the mileage.

75510 | ODO : N/A (tap to update)



NOTE: Please be aware that correct mileage is necessary to generate accurate diagnostic reports.

SCANNING A VEHICLE

Never replace a part based only on the DTC definition. Each DTC has a set of testing procedures, instructions and flow charts that must be followed to confirm the location of the problem. Always refer to the vehicle's service manual for detailed testing instructions.



NOTE: Check the vehicle thoroughly before performing any test.



WARNING: ALWAYS observe safety precautions whenever working on a vehicle.

Refer to the appropriate diagnostic test you wish to perform:

- **OB2 II Diagnostics** – [[See page 17](#)]
- **OEM Diagnostics** – [[See page 40](#)]
- **Workshop Tools** – [[See page 59](#)]

Retrieving and using Diagnostic Trouble Codes (DTCs) for troubleshooting vehicle operation is only one part of an overall diagnostic strategy.

OBD II DIAGNOSTICS

The **OBD II Diagnostics** function allows you to perform OBD II scans, view and record Live Data, create a RepairSolutionsPRO® Report, erase OBD II DTCs and perform other functions in the 10 OBD II Modes.



PERFORMING A SCAN - OBD II DIAGNOSTICS

1. Follow the **AutoLink Connection** steps to connect the tablet to your vehicle. [See page 15]
2. From the Home screen, tap **OBD II Diagnostics**.
 - A “Retrieving Vehicle Information...” message displays while the tablet checks the vehicle’s computer.

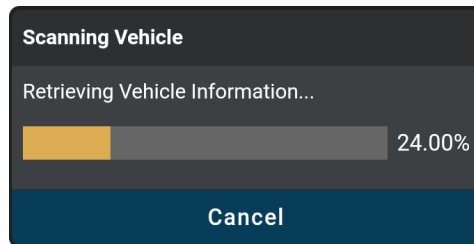

- If the tablet fails to link to the vehicle’s computer, a “Scan Failed” message displays.
 - Ensure the vehicle is OBD II compliant - check the Vehicle Emission Control Information (VECI) label located in the vehicle’s engine compartment.
 - Verify the connection at the DLC, and verify the ignition is ON.
 - Turn the ignition OFF, wait 5 seconds, then back ON to reset the computer.
 - Tap **Try Again** to try again, or tap **Cancel** to return to the Home screen.
3. When the retrieval process is complete, the **OBD II Diagnostics** screen displays the scan results.

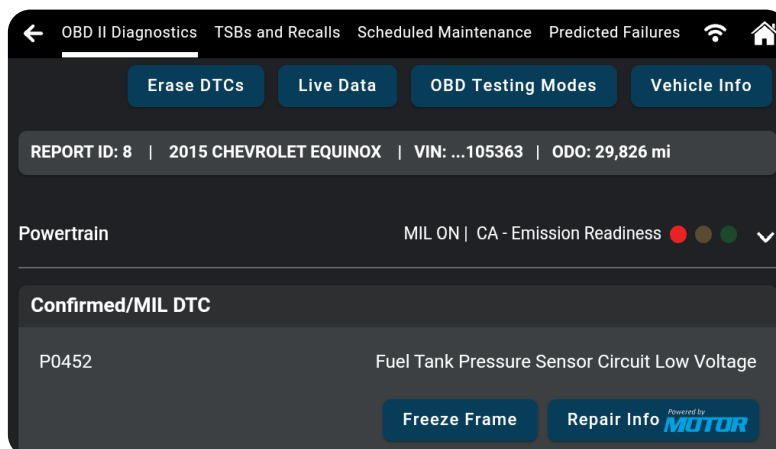

VIEWING SCAN RESULTS – OBD II DIAGNOSTICS

Scan results are shown immediately following completion of a scan; and can also be viewed later using the **PREVIOUS VEHICLES** function available through the Home screen. [See page 104]

Scan results are shown in a multi-page display, which includes **OBD II Diagnostics**, **TSBs and Recalls**, **Scheduled Maintenance**, and **Predicted Failures**.

Each report begins with a vehicle information bar that includes a **Report ID**, the vehicle's description (**year/make/model**), the last six digits of the **Vehicle Identification Number (VIN)** and the **odometer reading (ODO)** at the time the scan was performed.

REPORT ID: 2 | 2018 FORD EXPLORER | VIN: ...A75690 | ODO: 39,999 Mi

EMISSIONS READINESS – Interpreting Results

Indicates whether the vehicle is ready for an Emissions Test (Smog Check) through a “traffic light” type display. When viewing the **Emission Readiness** field, use the following definitions to identify the vehicle's Emissions Test readiness status:

Powertrain

MIL ON | CA - Emission Readiness ● ● ● ▼

- **MIL ON (or OFF)** – Displays the vehicle's Malfunction Indicator Light (MIL) status.
- **CA (California)** – Displays the acronym of I/M program location.
- **Green** – Indicates all engine systems are operating normally. The vehicle is ready for an Emissions Test (Smog Check), and there is a good possibility it can be certified.
- **Yellow** – Indicates one of the following two conditions is present:
 - A **“Pending”** Diagnostic Trouble Code is present. It is possible the vehicle can be tested for emissions and certified. Many areas (states / countries) allow an Emissions Test to be performed if the only code present is a “PENDING” code.
 - One or more Monitors *“Have Not Run”* their diagnostic testing. The issue of the vehicle being ready for an Emissions Test will depend on the emissions regulations and laws of your local area.
 - Some areas require that all Monitors indicate a *“Has Run”* status before an Emissions Test (Smog Check) can be performed. Other areas only require that some, but not all, Monitors indicate a *“Has Run”* status before an Emissions Test can be performed.
- **Red** – Indicates there is a problem with one or more of the vehicle's systems, and Diagnostic Trouble Code(s) (DTCs) are present. The vehicle is not ready for an Emissions Test. The problem(s) that caused the DTCs to set must be repaired before an Emissions Test can be performed.

CONFIRMED/MIL DTC

This is the code that has commanded the vehicle's Malfunction Indicator Light (MIL) "on," and is the code for which Freeze Frame data stored. This field includes the DTC number, description, and MIL status (ON or OFF).

- In OBD II systems, when an emissions-related engine malfunction occurs that causes a DTC to set, a record or snapshot of engine conditions at the time that the malfunction occurred is also saved in the vehicle's computer memory. The record saved is called Freeze Frame data.

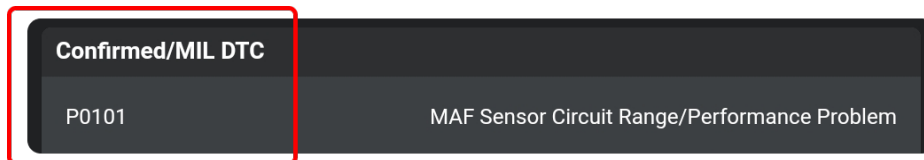

REPAIR INFO POWERED BY MOTOR

Innova has partnered with MOTOR Information Systems, a prominent automotive data provider, to deliver more efficient access to a broad range of content, including **DTC Troubleshooting**, **Wiring Diagrams**, **Component Locator**, **Specifications**, and additional valuable information. This service is currently offered for Confirmed/MIL DTC.

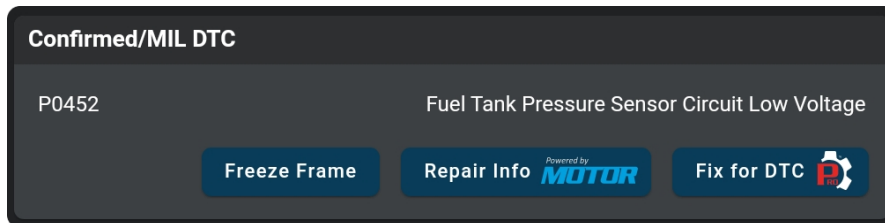

1. Tap the **Repair Info Powered by MOTOR** button on the OBD II Diagnostics screen.



NOTE: Verify the tablet is registered to the *RepairSolutionsPRO®* app.

- If you haven't registered for the RSPRO app yet or if you are logged out, a screen will display, asking you to either log in to your account or create a new one.
- The tablet also verifies if it's connected to a Wi-Fi network.

2. A "confirmation" screen displays. Tap **Continue**.

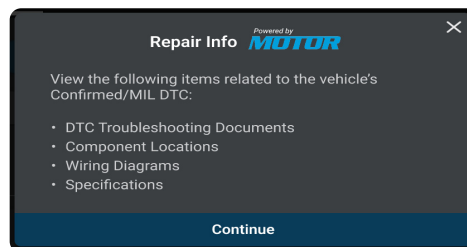

3. The next screen shows the available plans: 1 report, 15 reports, and 50 reports. Select your plan and tap **Continue**.

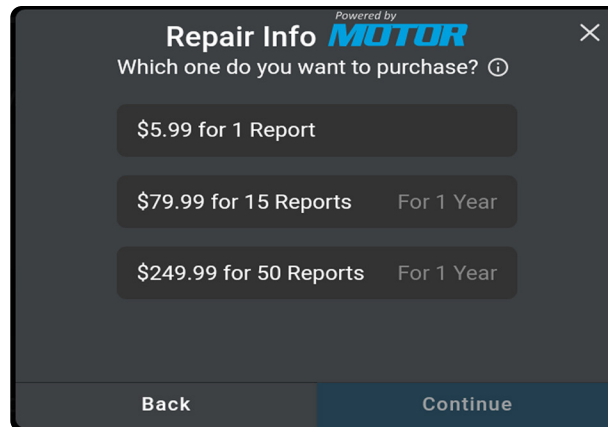

- If you choose one of the three plans for 1 report, 15 reports, or 50 reports, an "advisory" message displays.
 - After reading both the "OEM supplied" and "Terms & Conditions" information, the checkbox will be enabled. Check it and then tap **Continue**.

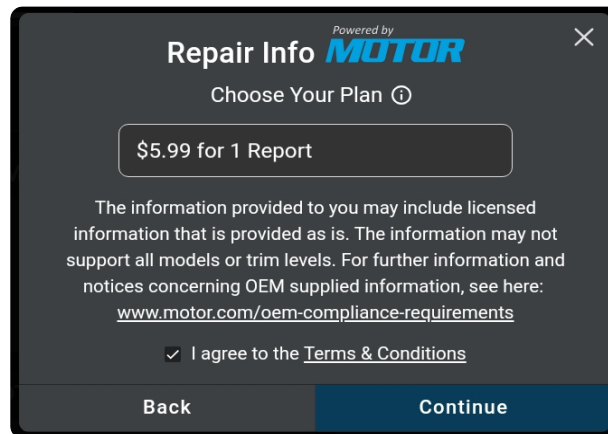

- The "confirmation" screen displays to verify your purchase.

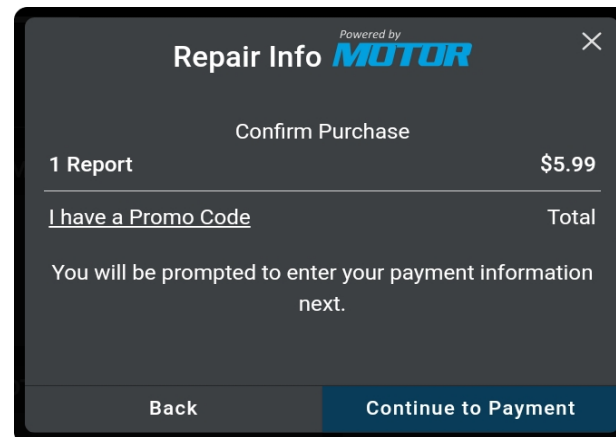

- Tap **Continue to Payment** and the Payment Details screen displays.

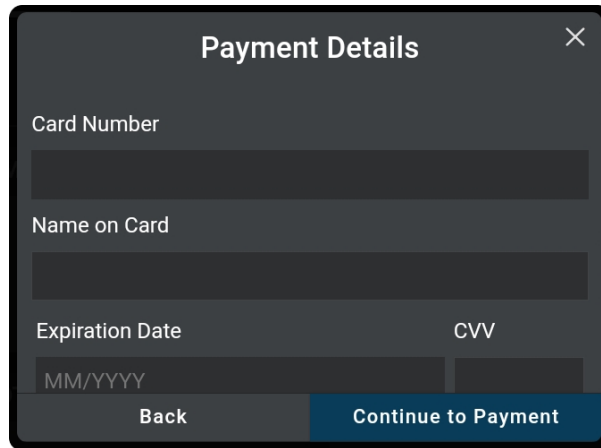

- Enter your payment information and tap **Continue to Payment**. Proceed to **step 5**.

5. Once the purchase is completed, the success screen displays.

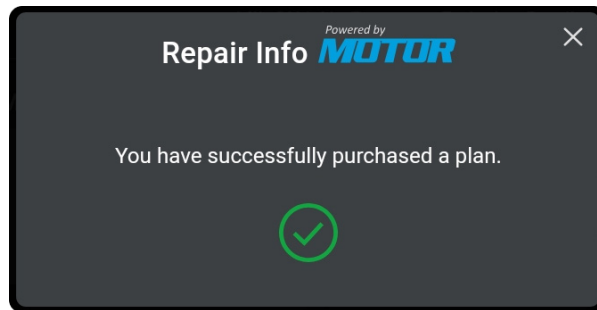

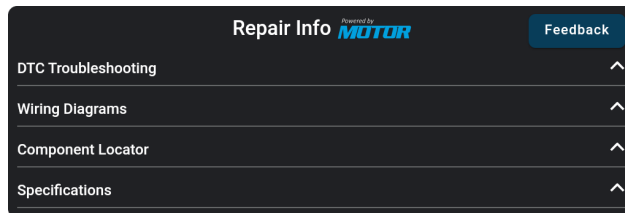

6. Tap the **x** button to continue. The “One moment screen...” screen displays while the tablet retrieves information.

7. Once completed, the tablet displays the Repair Info Powered by MOTOR, including **DTC Troubleshooting**, **Wiring Diagrams**, **Component Locator** and **Specifications**.

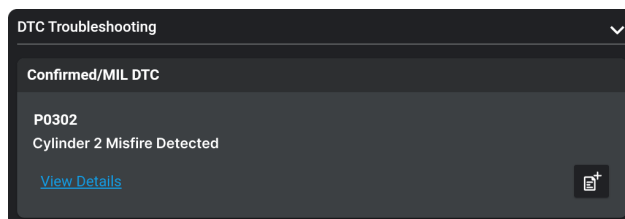

- **DTC Troubleshooting**: Get detailed descriptions, possible causes, diagnostic tips, and practical applications. This gives you all the technical info you need about the components linked to the DTC.



- Press the **View Details** hyperlink button to view DTC Troubleshooting information.
 - Press  to search for additional off-page references related to the next steps for DTC Troubleshooting.
 - **Wiring Diagrams:** Access clear and complete wiring diagrams for all the sensors and components you'll be working on, making your electrical repairs much easier.
 - **Component Locator:** Find the exact location of every part with easy-to-understand images, based on the vehicle's layout. This ensures you can fix things quickly and accurately.
 - **Specifications:** Get all the important data such as torque specs, voltage standards, and more to make sure you're replacing parts correctly.
8. Press the **Feedback** button to share your experience using the Repair Information feature.

FIX FOR DTC (RSPRO®)

POWERED BY



Innova's **RepairSolutionsPRO®** (RSPRO®) reports offer a fix, which is cross referenced for accuracy against a database of millions of verified fixes. It is real-world data that has been collected for over 25 years by Innova's network of ASE Master Technicians across the U.S.



NOTE: *Certain fields and pages require that you create a RepairSolutionsPRO® report to access, download and display the associated "enhanced" data.*

1. Tap the **Fix for DTC** button on the OBD II Diagnostics screen.



NOTE: *Verify the tablet is registered to the RepairSolutionsPRO® app.*

- If you haven't registered for the RSPRO® app yet or if you are logged out, a screen displays, asking you to either log in to your account or create a new one.

2. With the tablet paired and registered with the RepairSolutionsPRO® app:

- The tablet verifies if it's connected to a Wi-Fi network.



NOTE: *The tablet can be connected to a Wi-Fi network by using the RepairSolutionsPRO® app, or by using the Settings tab on the tablet. [See page 112]*

3. The tablet displays the *Fix for DTC* screen, and includes:

Fix for DTCs

Most Likely Component/System Cause for DTC Repair Tip

Replace Fuel Tank Pressure (FTP) Sensor

Fuel Tank Pressure Sensor	\$98.44
---------------------------	---------

Technician Comments

[More Possible Fixes](#) ▼

Did this fix the car? ⓘ

Yes
No

Most Likely Component/System Cause for the DTC

- Includes recommended parts, cost, and a **Buy Part** button.
- Second Most Likely Component/System Cause for the DTC.
- Third Most Likely Component/System Cause for the DTC.
 - Swipe down to view other potential fixes (if available).
- Other Likely Component/System Cause for the DTC.



NOTE: The **Buy Part** button can be activated or disabled in the Settings tab under the RSPRO® Settings. [See page 111]

Technician Comments

The Technician Comments offers expert notes or helpful inspection suggestions from master technicians.

1. Tap the **Technician Comments** button on the Fix for DTC screen.
 - The Technician Comments for the potential fix displays.

Technician Comments

Name: Replace Fuel Tank Pressure (FTP) Sensor

Description: KOEO, use the scan tool to view the FTP sensor data, should be close to 0, if not, remove the gas cap and check, must be very close to 0.0 or 1.5 V, if not, replace the FTP and retest.

Tips/Tricks: check for debris/water or corrosion in the FTP connector, check the X112 connector, In the right rear of the engine compartment, inside the right front strut tower for debris or corrosion check the X350 connector, Under the vehicle, near the left rear wheel, this contains wiring for fuel pump and FPCM.

[Close](#)

2. When finished viewing, tap the **Close** button to return to the Fix for DTC screen.

Repair Tip

The Repair Tip offers additional insight and helpful tips to resolve the issue.

1. Tap the **Repair Tip** button on the Fix for DTC screen.
 - The Repair Tip menu for the retrieved DTC displays.

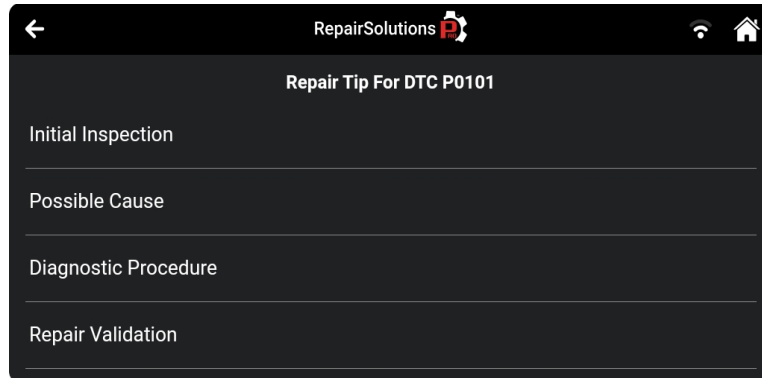

- Each Repair Tip for DTC includes: Initial Inspection, Possible Cause, Diagnostic Procedure and Repair Validation.
 - Select the information you wish to view.
 - When finished viewing, tap the **Back** button to return to the Repair Tip menu.

Did this fix the car?

- Users will be prompted to select which likely fix resolved their vehicle's DTC.
- Help other technicians find the best DTC solutions. Validate the provided fixes to ensure that we continue to improve and maintain the most accurate fix database on the market.

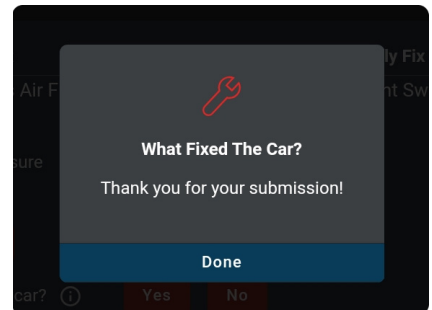

MONITOR STATUS

Shows the current status for all **Monitors** supported by the vehicle. Available Monitors are listed and identified as follows (*The CCM - Comprehensive Component Monitor is being used as an example.*):

Green Solid Icon = CCM

Description: This icon indicates the Monitor has completed both Since DTCs Cleared (KOEO) and This Driving Cycle testing (KOER).

Tips: The Monitor has met all conditions required to complete self-diagnosis and testing of the assigned system.

Red Solid Icon = CCM

Description: This icon indicates that the Monitor has not completed testing Since DTCs Cleared (KOEO).

Tips: The Monitor has not met all conditions required to complete self-diagnosis and testing of the assigned system. A drive cycle may need to be performed to complete the testing.

[View Glossary](#)

Monitor Status - This Driving Cycle

MIS	Misfire Monitor
FUE	Fuel System Monitor
CCM	Comprehensive Component Monitor (CCM)
CAT	Catalyst Monitor
EVA	EVAP System Monitor

Green/Gray Solid Icon = CCM

Description: This icon indicates that the Monitor has not completed testing This Driving Cycle (KOER).

Tips: The Monitor has not met all conditions required to complete self-diagnosis and testing of the assigned system. A drive cycle may need to be performed to complete the testing.

Red/Gray Solid Icon = CCM

Description: This icon indicates that the Monitor has been disabled This Driving Cycle (KOER).

Tips: The Monitor is unable to complete self-diagnosis and testing of the assigned system. The Monitor is disabled for this driving cycle, check for failed OBD Monitor Test and refer to the service information before continuing.

CONFIRMED DTC

Shows all “confirmed” powertrain DTCs for the vehicle. Each entry in the list includes the DTC number and description.

In addition to Confirmed/MIL DTC, the tablet provides troubleshooting information for two additional confirmed DTCs once you’ve purchased the MOTOR data report in the Confirmed/MIL DTC section.

Refer to Repair Info Powered by MOTOR. [\[See page 19\]](#)

PENDING DTC

Shows all “pending” powertrain DTCs for the vehicle. Each entry in the list includes the DTC number and description.

PERMANENT DTC

Shows all “permanent” powertrain DTCs for the vehicle. Each entry in the list includes the DTC number and description

For vehicles from 2010 and subsequent, meeting specific Permanent DTC (PDTC) criteria is a new requirement of the Smog Check program in California. Permanent DTCs are similar to regular DTCs, but they cannot be reset by disconnecting the vehicle’s battery or cleared with an On-Board Diagnostic scan tool. PDTCs will only be ignored if the vehicle has completed at least 15 warm-up cycles and driven at least 200 miles since its OBD information was last cleared.

1. If the vehicle meets the criteria to pass the Smog Check, the Permanent DTC will be ignored.
2. If the vehicle does not meet the criteria to pass the Smog Check, follow the PDTC PIDs and Drive Cycle Procedures to ensure it meets the requirements for PDTCs to be ignored.
 - Tap the **PDTC PIDs** button.

Confirmed DTC

P0220 Throttle Position Sensor 2
Circuit

P2122 Accelerator Pedal Position
(APP) Sensor 1 Circuit Low
Voltage

Pending DTC

P1233 Fuel Pump Driver Module
Disabled Or Off Line (Fuel
Pump Driver Module)

P0302 Cylinder 2 Misfire Detected

Permanent DTC

The criteria to PASS a California Smog Check has NOT been met, the Permanent DTC will require 15 warm-up cycles and 200 miles to pass the inspection.

Please refer to the California Bureau of Automotive Repair website for additional information: bar.ca.gov.

P0102 Mass or Volume Air Flow
Sensor 'A' Circuit Low

P0113 Intake Air Temperature
Sensor 1 Circuit High Bank 1

PDTC PIDs

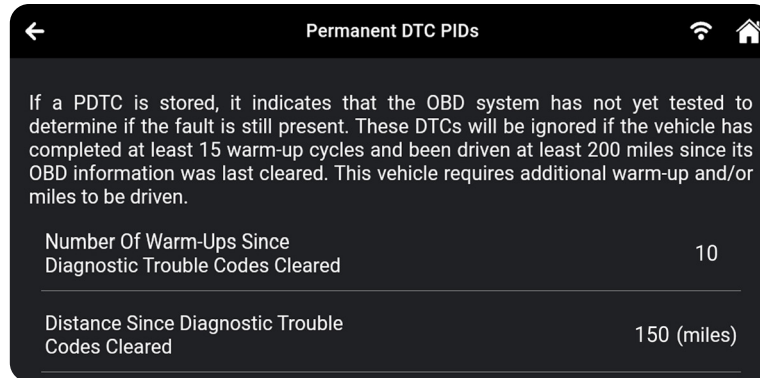

ADDITIONAL TESTING UTILITIES

The following utilities are also included under the **OBD II DIAGNOSTICS** scan results.

ERASE DTCS - MODE \$04



NOTE: When the Erase function is used to erase DTCs from the vehicle's on-board computer, "Freeze Frame" data and manufacturer-specific-enhanced data are also erased. "Permanent" DTCs ARE NOT erased by the Erase function.



NOTE: When DTCs are erased, the I/M Readiness Monitor Status program resets the status of all Monitors to a not run condition. To set all Monitors to a COMPLETE status, an OBD II Drive Cycle must be performed.

Erase DTCs from the vehicle's computer memory as follows:

1. Connect to the vehicle by following the steps for PERFORMING A SCAN - OBD II Diagnostics. [\[See page 17\]](#)
2. Tap the **Erase DTCs** button at the top of the OBD II Diagnostic results page.
 - The tablet displays an "attention" message to confirm the deletion.
 - If you want to proceed, tap **Erase DTCs** to continue.
 - If you do not want to proceed, tap **Cancel** to exit the erase procedure.
3. When **Erase DTCs** is selected, a "One moment please..." progress message displays during the erase process.
 - If the erase was successful, a "confirmation" message displays.
 - After 3 seconds, the tablet automatically re-scans the vehicle to confirm DTC deletion.
4. If the erase was not successful, an "advisory" message displays indicating to either:
 - Place the vehicle in the Key ON, Engine OFF position.
 - Place the vehicle in park or neutral; set the parking brake; and start the engine.

LIVE DATA - MODE \$01

The tablet allows you view and/or record “real-time” Live Data for further vehicle analysis. This information includes values (volts, rpm, temperature, speed, etc.) and system status information (open loop, closed loop, fuel system status, etc.) generated by the various vehicle sensors, switches, and actuators.

The real time (Live Data) vehicle operating information (values/status) that the computer supplies to the tablet for each sensor, actuator, switch, etc. is called **Parameter Identification (PID) data**.

Each PID (sensor, actuator switch, status, etc.) has a set of operating characteristics and features (parameters) that serve to identify it. The tablet displays this information for each sensor, actuator, switch, or status that is supported by the vehicle under test.



DANGER: *If the vehicle must be driven to perform a troubleshooting procedure, ALWAYS have a second person help you. One person should drive the vehicle while the other person observes the tablet data. Trying to drive and operate the tablet at the same time is dangerous and could cause a serious injury to you and bystanders.*

Viewing Live Data

1. Connect to the vehicle by following the steps for PERFORMING A SCAN - OBd II Diagnostics. [\[See page 17\]](#)
2. While linked to the vehicle, start the engine.
3. Tap the **Live Data** button at the top of the OBd II Diagnostic results page to place the tablet in Live Data mode.
 - A progress message displays while the vehicle is scanned, and Live Data mode is activated.
 - Tap **Cancel** to exit the procedure.
4. The results screen displays all of the vehicle’s available PIDs with reported values. Each PID is unselected to offer customization on which component you wish to select and explore further.

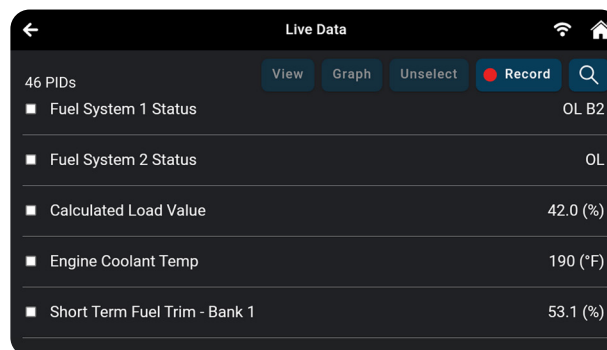



NOTE: *The View, Graph, and Unselect buttons remain “disabled” until a PID is selected from the list.*

5. Select the **PID(s)** you wish to explore.
 - A “checkmark” indicates the associated PID *is selected* for viewing.

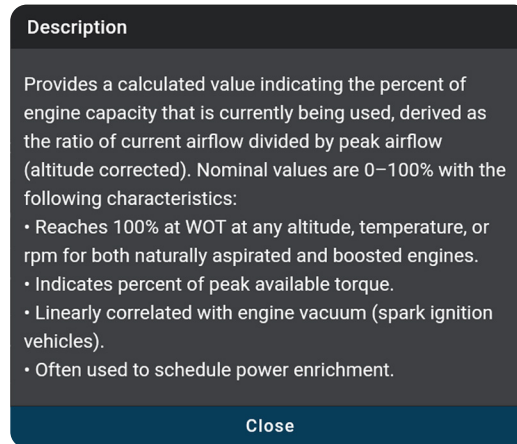
- An “empty checkbox” indicates the PID is *not selected* for viewing.
 - Tapping a checkbox repeatedly will toggle it on and off.
 - Tap the **Unselect** button to unselect *all* PIDs.
6. Tap and hold the **PID** to expand its definition and description.



7. Tap the “**search**”  icon to quickly search for the PID(s) you wish to view or graph.
- Use the keyboard to type in the name of the PID(s) and select as desired.
 - Tap the “**hide search**”  icon to exit the search function and return to the PID list.
8. Tap the **View** button to view data for the selected PIDs in tabular mode.
- Each entry in the table shows the name of the PID, and a numerical representation of the current value for the PID.
 - Tap **PID List** to return to the full PID results list. (*Step 5 above*)
9. Tap the **Graph** button to view the selected PIDs in graph mode.

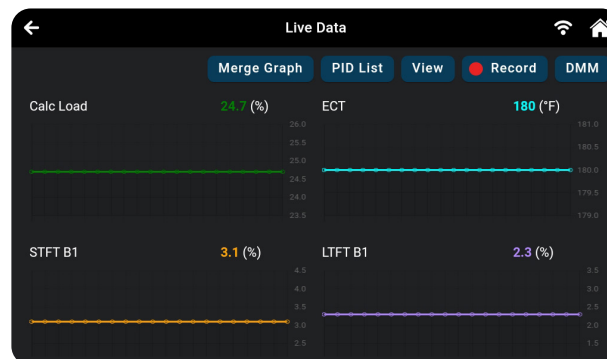

NOTE: The Graph function button will stay inactive if the selected PID does not report a numerical value. An example is the Fuel System Status PID, which reports either Open Loop (OL) or Closed Loop (CL).

10. Tap the **Merge Graph** button to view more PIDs on a single graph.

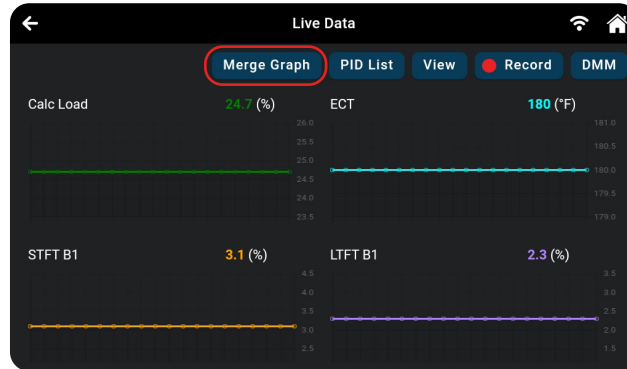

11. Tap the **Multi Graph** button to go back to the selected PIDs in graph mode.

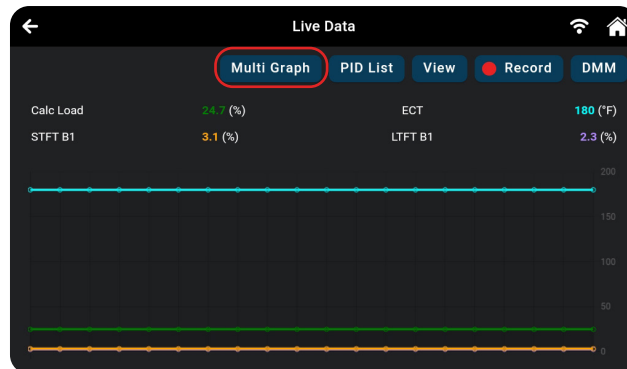

12. Tap the **Record** button to record the selected PIDs in real time. [See page 29]



NOTE: Tapping the **Record** button without selecting any PIDs will record **all** of the vehicle's available PIDs.

13. When troubleshooting vehicle problems, use the Live Data / PID results displayed on the tablet and compare them against the specifications found in the vehicle's repair manual.
14. Tap the ← icon to return to the *OBD II Diagnostics* results page, or the 🏠 **Home** icon to exit.

Recording (Capturing) Live Data

The tablet allows you to record and save Live Data information for each PID supported by the vehicle.

1. Place the tablet in Live Data mode as indicated in **Live Data Mode**. [See page 27]
2. Tap **Record** to begin recording Live Data. Tap **Stop** to stop recording.
3. A "Recording Complete" dialog displays the message "Would you like to save the recorded live data?"
 - Tap **Yes, Save Live Data** to save the recorded data to the tablet's memory for later playback [See page 106].
 - Tap **No, Erase Live Data** to discard the recorded data.

OBD TESTING MODES

OBD Testing Modes are accessed from the **OBD II Diagnostics** results page. [[See page 17](#)]

1. Tap the **OBD Testing Modes** button at the top of the OBD II Diagnostics results page.

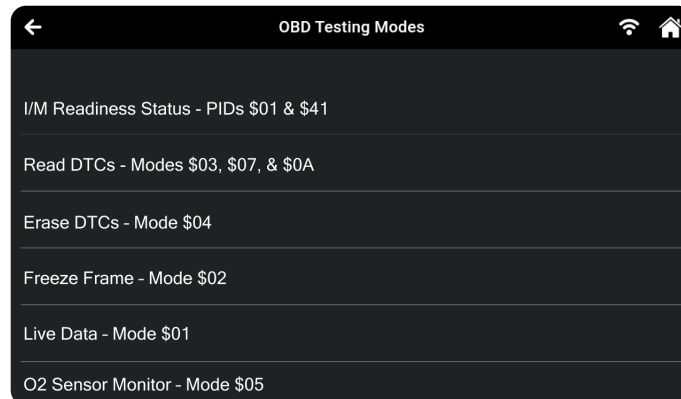

2. The OBD Testing Modes screen displays with the following options:
 - **I/M Readiness Status - PIDs \$01 & \$41** – Lets you view the drive cycle procedures for all Monitors supported by the vehicle in Since DTC Cleared or This Driving Cycle. [[See page 30](#)]
 - **Read DTCs - Modes \$03, \$07 & \$0A** – Lets you view the OBD II DTCs. [[See page 17](#)]
 - **Erase DTCs - Mode \$04** – Lets you erase DTCs from the vehicle's computer memory. [[See page 26](#)]
 - **Freeze Frame - Mode \$02** – Lets you view Freeze Frame data stored in the vehicle's computer. [[See page 32](#)]
 - **Live Data - Mode \$01** – Lets you view real-time Live Data. [[See page 27](#)]
 - **O2 Sensor Monitor - Mode \$05** – Retrieves and displays O2 sensor monitor test results from the vehicle's on-board computer. [[See page 32](#)]
 - **OBD Monitor Test - Mode \$06** – Retrieves test results for emission-related powertrain components and systems that are not continuously monitored. [[See page 32](#)]
 - **Request Control On-Board System - Mode \$08** – Lets you perform an EVAP Test or Particulate Filter Regeneration and Inducement System Reinitialization. [[See page 33](#)]
 - **Drive Cycle Procedures** – Lets you view the Drive Cycle Procedures for a Monitor. [[See page 34](#)]
 - **Vehicle Enhance Information - Mode \$09** – Lets you retrieve reference information for vehicle under test. [[See page 34](#)]

I/M Readiness Status - PIDs \$01 & \$41

The vehicle's computer stores a record of Monitor status upon completion of a full diagnostic check of all monitored components and systems since the computer's memory was last cleared.

The **I/M Readiness Status - PIDs \$01 & \$41** feature displays which particular vehicle Monitor(s) have or have not run and completed testing of their designated sections within the vehicle's emissions control system. Additionally, it also provides the descriptions for each Monitor.

- From the Monitor Status field on the OBD II Diagnostic page, tap the **View Drive Cycles** button, or, from OBD Testing Modes menu, tap **I/M Readiness Status - PIDs \$01 & \$41**.
 - The I/M Readiness Status - PIDs \$01 & \$41 page displays. Select **Since DTCs Cleared** or **This Driving Cycle** as appropriate.

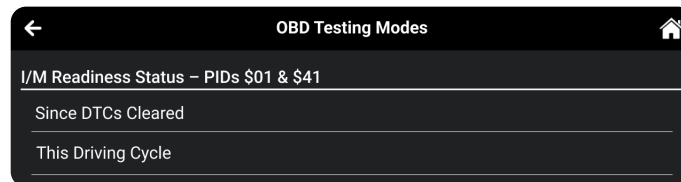

- If the vehicle under test does not support Since DTCs Cleared or This Driving Cycle, a “warning” dialog displays the message “This vehicle does not support this monitor type.” Tap the **Back** button to return to the previous dialog.
- The Select Monitor screen displays a list of all Monitors supported by the vehicle.
 - To view a Monitor description, tap the ⓘ **Info** icon .
 - To view Drive Cycle Procedures for a Monitor, tap the **View Drive Cycles** button.

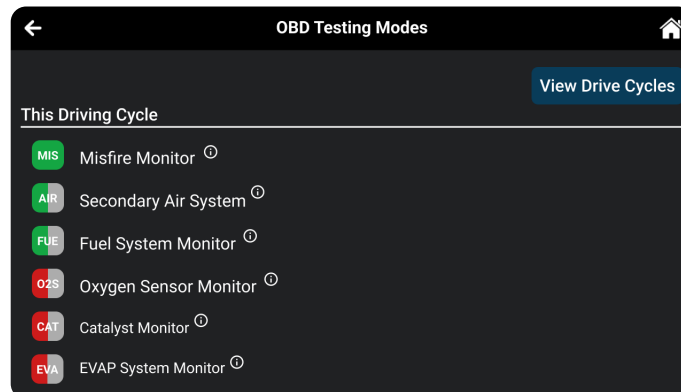

- The page refreshes to display the Drive Cycle procedure for the Incomplete or Enabled Monitors.

 **NOTE:** If Drive Cycle Procedures are not available for the vehicle, an “advisory” message displays.

- The Drive Cycle Procedure screen shows the specific set of operating procedures that ensure the vehicle is driven in such a way that all the required “Enabling Criteria” for the Monitor to run and complete its diagnostic testing are met.
- When you are finished viewing the Drive Cycle Procedures, tap the **Back** button to return to the previous dialog or tap the  **Home** button to return to the Home screen.

Freeze Frame - Mode \$02

Under Freeze Frame, saved engine conditions can include, but are not limited to engine speed, open or closed loop operation, fuel system commands, coolant temperature, calculated load value, fuel pressure, vehicle speed, air flow rate, and intake manifold pressure. These values are typically used to further diagnose and pinpoint the issue.

1. If a Confirmed/MIL DTC is present, the Freeze Frame button will display under the Confirmed/MIL DTC section. If not, select **Freeze Frame - Mode \$02** in the OBD Testing Modes screen.

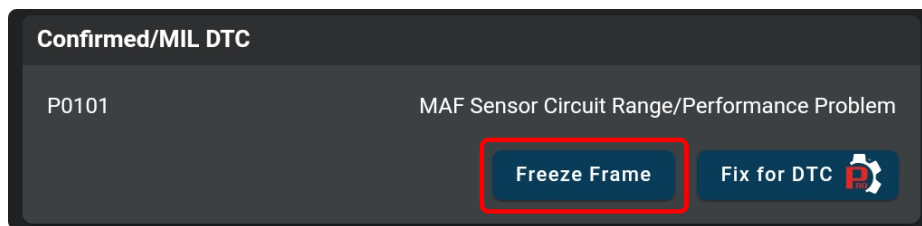

2. The Freeze Frame data screen displays.
3. When you are finished viewing the Freeze Frame data, tap the **Back** button to return to the previous dialog or tap the  **Home** button to return to the Home screen.

O2 Sensor Monitor - Mode \$05

The **O2 Sensor Monitor – Mode \$05** lets you view the test results of the vehicle's two or more O2 sensors. These sensors are designed to help identify problems that can reduce fuel efficiency or increase emissions. Each O2 sensor has a unique name that identifies its location in the exhaust system – cylinder bank location (bank 1 or bank 2) and its location in relation to the catalytic converter (*upstream* or *downstream*). Please reference the vehicle's service manual for further information.

 **NOTE:** Service Mode \$05 is not supported in ISO 15765-4 (CAN) applications – it includes the majority of 2008 and older vehicles. For CAN applications, the functionality of Service Mode \$05 was implemented in Service Mode \$06.

1. From the OBD Testing Modes screen, tap **O2 Sensor Monitor – Mode \$05**.
 - The Oxygen Sensor page displays.
2. Tap the **X** icon on the top right to return to the OBD Testing Modes selection screen.

OBD Monitor Test - Mode \$06

The **OBD Monitor Test - Mode \$06** retrieves and displays test results for emission-related powertrain components and systems that are not continuously monitored. The tests available are determined by the vehicle manufacturer.

 **NOTE:** The tablet does not perform the OBD Monitor Test. Instead, it retrieves results for the most recently performed tests from the on-board computer's memory.

1. From the OBD Testing Modes screen, tap **OBD Monitor Test - Mode \$06**.
2. When test results have been retrieved, the test results screen displays. The following information is provided for each available test:

- **Test ID** number
- **Component ID**
- **Test Value**
- **Min, Max** test limit
- **Unit of measurement**
- **Status**



NOTE: *Status* is calculated by the tablet by comparing the **Test Value** against the displayed test limit (**Min, Max**). **Status** is shown as either **Low, High** or **OK**.

3. Tap the **X** icon to close the test results screen and return to the OBD Testing Modes screen.

Request Control On-Board System - Mode \$08

The **Request Control On-Board System - Mode \$08** mode allows you perform an EVAP Test or Particulate Filter Regeneration and Inducement System Reinitialization.

- **EVAP Test** - Lets you initiate a leak test for the vehicle's EVAP system.
- **Particulate Filter Regeneration** - This service requests the vehicle to initiate a PF regeneration. The vehicle manufacturer is responsible to determine the criteria to enable, start and stop the function, such as engine running, vehicle speed, or engine rpm.
- **Inducement System Reinitialization** - This service requests the vehicle to initiate reinitialization of the inducement system. The vehicle manufacturer is responsible to determine the criteria to enable, start and stop the function, such as engine running, vehicle speed, or engine rpm.



NOTE: *The tablet does not perform the leak test, but signals to vehicle's on-board computer to initiate the test. The vehicle manufacturer determines the criteria and method for stopping the test once it has been started. BEFORE using the Request Control On-Board System function, refer to the vehicle's service manual to determine the procedures necessary to stop the test.*



NOTE: *Some vehicle manufacturers do not allow tablets or other external devices to control vehicle systems. If Request Control On-Board System is not supported by the vehicle under test, an "advisory" message displays. Tap the **Back** to return to the OBD Testing Mode.*

1. From the OBD Testing Modes screen, tap **Request Control On-Board System - Mode \$08**.
 - A Request Control On-Board System - Mode \$08 screen displays.



NOTE: *The EVAP Test is used for Spark Ignition vehicles, and the Particulate Filter Regeneration and Inducement System Reinitialization are used for Compression Ignition vehicles.*

2. Tap the test or function you wish to perform.
 - A "One moment please..." message displays while the tablet performs the test/function.

- When the test/function has been initiated by the vehicle's on-board computer, a "confirmation" message displays.

Drive Cycle Procedures

Drive Cycle Procedures lets you view the Drive Cycle Procedures for all Monitors supported by the vehicle.

- From the OBD Testing Modes, tap the **Drive Cycle Procedures** button.
 - The Drive Cycle Procedures page displays.
 - The Drive Cycle Monitors column on the left lists the Monitors supported by the vehicle.
 - The right column of the page shows the Drive Cycle Procedure for the currently selected Monitor.
- Tap a **Monitor name** to view the Drive Cycle Procedure for the selected Monitor.
 - The page refreshes to display Monitor information and the Drive Cycle Procedures for the selected Monitor.

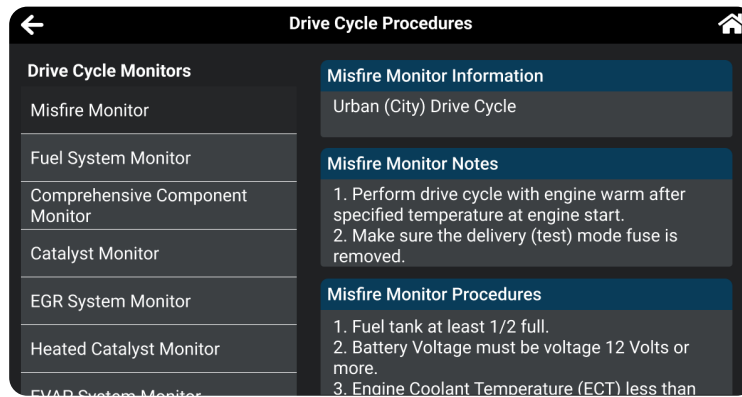

- Follow the steps provided to perform and complete the Monitor's "Enabling Criteria."

VEHICLE ENHANCE INFORMATION - MODE \$09

Vehicle Enhance Information - Mode \$09 allows you to view detailed vehicle identification and system-related information. It supports both All PIDs view and organized PID groups, with dynamic parameters streamed like live data and static info (VIN, calibration IDs, etc.) retrieved on demand. This helps you quickly check key vehicle details for diagnostics and verification.

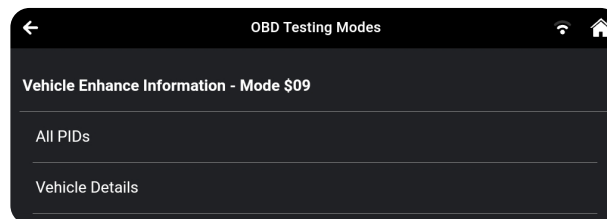

All PIDs

- From the OBD Testing Modes, tap the **Vehicle Enhance Information - Mode \$09** button.
 - The Vehicle Enhance Information - Mode \$09 menu displays.
- Tap **All PIDs**.
 - The All PIDs page displays.
- The results screen displays all of the vehicle's available PIDs with reported values. Each PID is unselected to offer customization on which component you wish to select and explore further.

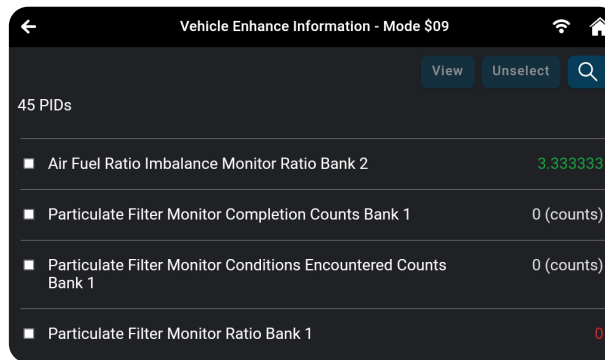



- Status indication using Red/Green color coding is applied only to Ratio-related PIDs.
 - Green** - Indicates the monitored condition is met and the PID value is within the expected ratio range.
 - Red** - Indicates the monitored condition is not met or the PID value is outside the expected ratio range.

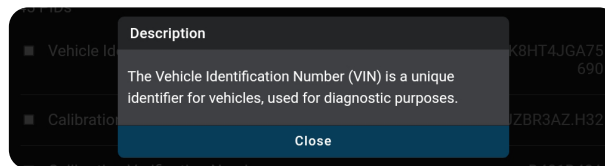

NOTE: The View, and Unselect buttons remain “disabled” until a PID is selected from the list.

- Tap and hold a **PID** to expand its definition and description.



- Select the **PID(s)** you wish to explore.
 - A “checkmark” indicates the associated PID *is selected* for viewing.
 - An “empty checkbox” indicates the PID is *not selected* for viewing.
 - Tapping a checkbox repeatedly will toggle it on and off.
 - Tap the **Unselect** button to unselect *all* PIDs.
- Tap the “**search**”  icon to quickly search for the PID(s) you wish to view.
 - Use the keyboard to type in the name of the PID(s) and select as desired.
 - Tap the “**hide search**”  icon to exit the search function and return to the PID list.

7. Tap the **View** button to view data for the selected PIDs in tabular mode.
 - Each entry in the table shows the name of the PID, and a numerical representation of the current value for the PID.
 - Tap **PID List** to return to the full PID results list. (*Step 3 above*)

Vehicle Details

The Vehicle Details function provides an extensive list of in-depth technical data, such as battery information, body style, door count, and drivetrain type, presented as corresponding codes and descriptions.

1. From the OBD Testing Modes, tap the **Vehicle Enhance Information - Mode \$09** button.
 - The Vehicle Enhance Information - Mode \$09 menu displays.
2. Tap **Vehicle Details**.
 - The Vehicle Details page displays.

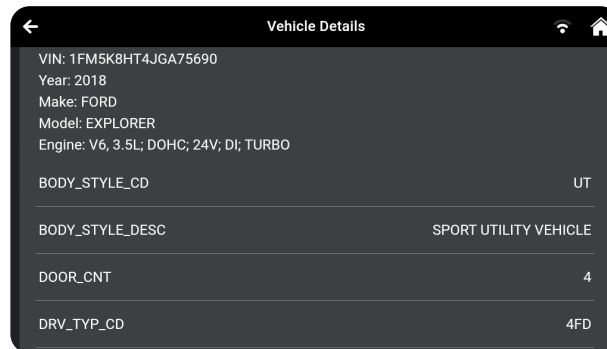

VEHICLE INFO

The **OBD II DIAGNOSTICS** test results page includes additional information, which can be accessed by tapping the **Vehicle Info** button on the results page. This page allows you to view **Vehicle Details**, **Customer Information**, **Vehicle ID**, **Available Modules**, and **In-Use Performance Tracking (IPT)**.

1. Tap the **Vehicle Info** button at the top of the OBD II Diagnostic results page.
2. A dialog screen displays. Scroll to view each section.

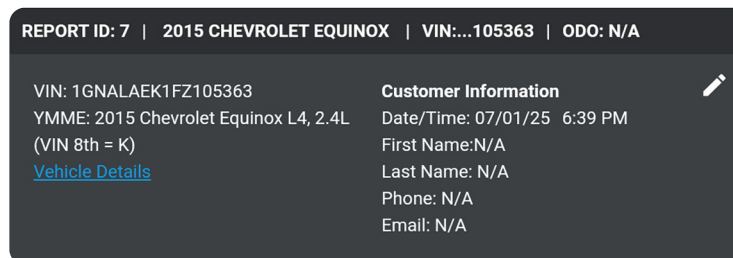

- **Additional Vehicle Information** – Offers basic information such as the VIN and Year, Make and Model of the vehicle. More details are accessible with the Vehicle Information button.
- **Vehicle Details** – [[See page 36](#)]

- **Customer Information** – Includes the Date/Time at which the scan was performed and the customer’s information, which can be edited using the  icon. [See page 38]

Vehicle ID

The Vehicle ID section displays the following information:

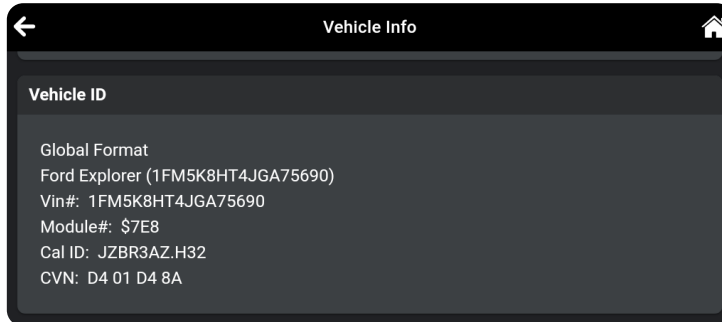

- **VIN:** The complete Vehicle Identification Number.
- **YMME:** The vehicle’s year, make, model and engine.
- **Module No:** The control module identification number(s).
- **Cal ID:** The vehicle’s calibration ID(s). These IDs uniquely identify the software version(s) for the vehicle’s control module(s).
- **CVN:** The Vehicle’s Calibration Verification Number(s) (CVNs) required by OBD II regulations. CVNs are used to determine if emission-related calibrations for the vehicle under test have been changed.

Available Modules

The Available Modules section displays the following information:

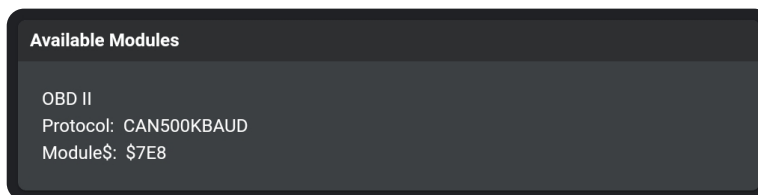

- **OBD II:** Confirms the vehicle’s on-board diagnostic system is OBD II compliant.
- **Protocol:** Lists the vehicle’s OBD II communication protocol. This can be either ISO 9141, Keyword 2000, J1850 PWM, J1850 VPW or CAN.
- **Module\$:** Lists the primary control module’s identification number.

In-Use Performance Tracking (IPT)

The tablet can retrieve In-Use Performance Tracking (IPT) statistics for Monitors supported by the vehicle under test. Two values are returned for each Monitor; the number of times that all conditions necessary for a specific

Monitor to detect a malfunction have been encountered (XXXCOND), and the number of times that the vehicle has been operated under the specific conditions for the Monitor (XXXCOMP). Statistics are also provided for the number of times the vehicle has been operated in OBD monitoring conditions (OBDCOND), and the number of times the vehicle's engine has been started (IGNCNTR).

In-Use Performance Tracking	
Description	Count
OBDCOND	516
IGNCNTR	1717
CATCOMP1	572
CATCOND1	516

EDITING CUSTOMER INFORMATION

Each vehicle scan can be personalized by adding the customer's information, including their **First Name**, **Last Name**, **Phone** and **Email**.

1. Tap the  icon to display the Edit Customer Information fields.
2. Tap the field you wish to edit, then enter the desired value using the keyboard.
 - Enter the **Phone number (including area code) as a 10-digit number**, without spaces or other characters (*Example: 8005551212*).
 - Be sure to use a properly formatted Email address (*Example: yourname@gmail.com*).
3. When all desired information has been entered, tap **Save** to save your changes.
 - A "confirmation" message displays when customer information has been successfully saved.
 - If an invalid Phone number or Email address has been entered, an "advisory" message displays. Tap **Close** to return to the Edit Customer Information fields. Make the necessary correction(s), then tap **Save** to save your changes.

Enter Customer Information

First Name

Last Name

Phone

Email

Save
Cancel

TSBs AND RECALLS

The **TSBs and Recalls** page provides a listing of all Technical Service Bulletins (TSBs) and Recalls issued against the vehicle.

TSBs and Recalls are grouped in categories (NHTSA Recalls, Body TSBs, Electrical TSBs, Factory Recalls, etc.). The number of items in each category is shown following the category name.

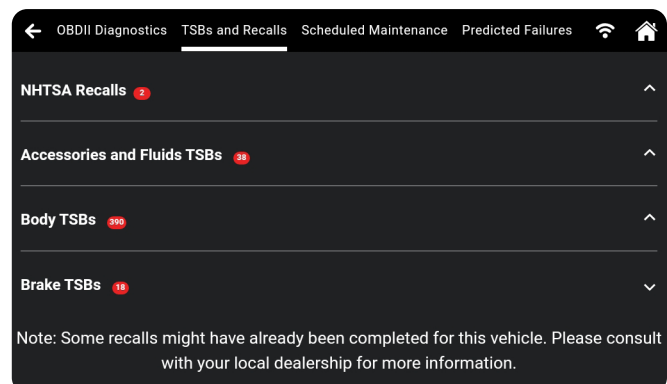

Tap the  icon for a category to expand the category and view the full text of the associated TSBs or Recalls.



NOTE: Some TSBs and/or Recalls for the vehicle may have already been accomplished.

SCHEDULED MAINTENANCE

The **Scheduled Maintenance** page provides a listing of scheduled maintenance procedures due at the next service interval. The **Next Service** field shows the odometer reading at which the associated service procedures are due.

Each entry in the list shows a scheduled inspection or repair/ replacement procedure. In cases of replacement procedures, the entry shows the required replacement part(s), the “per unit” part cost, and the number of parts required for the procedure.

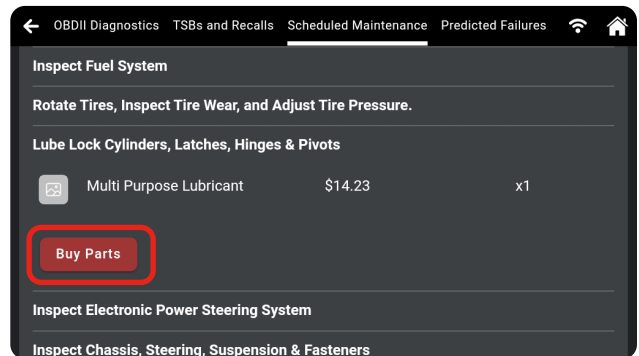

Tap the **Buy Parts** button to access the web page for your preferred online parts supplier.



NOTE: The tablet uses the value entered in the **Retailer** section of the **SETTINGS** page to determine your preferred parts supplier. [\[See page 111\]](#)

PREDICTED FAILURES

The **Predicted Failures** page provides a listing of components and systems that may experience a failure within the next 12-month period. Each is based on historical data taken from millions of real-world vehicle repair records collected for over 25 years by Innova’s network of ASE Master Technicians across the U.S.

Each entry in the list provides the following information:

- **Predicted Failure(s) within 12 months:** A brief description of the predicted failure/repair/maintenance procedure required.
- **Probability of Failure:** Expressed as a percentage of 100; shows a bar graph and numerical value. The higher the value, the more likely the failure will occur.
- **Price:** Estimated cost to accomplish the associated repair/maintenance procedure.

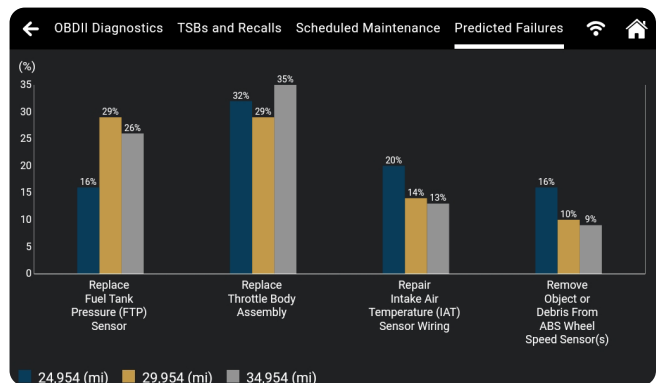

OEM DIAGNOSTICS

The **OEM Diagnostics** function allows you to perform enhanced, OEM level diagnostics not available over generic OBD II. Access ABS, Airbag, Transmission, Tire Pressure, Battery, and many body control modules to view and erase their DTCs. Perform bi-directional tests on fuel pumps, injectors, ignition coils, and much more. Plus, get access to hundreds of additional parameters that you can view in real-time.



PERFORMING A SCAN – OEM DIAGNOSTICS

1. Follow the **AutoLink Connection** steps to connect to the vehicle [See page 15].
2. From the Home screen, tap **OEM Diagnostics**.
3. A “selection” dialog displays.
4. Select the type of test you wish to perform.

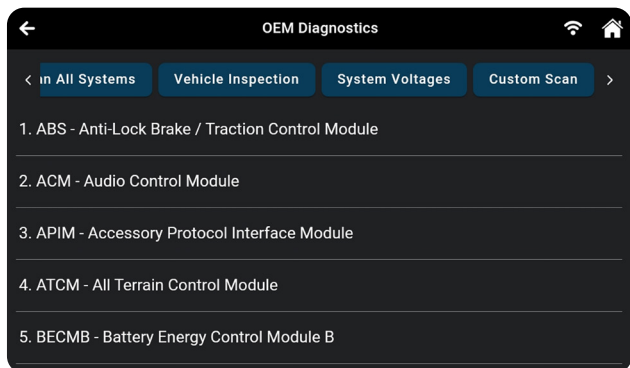
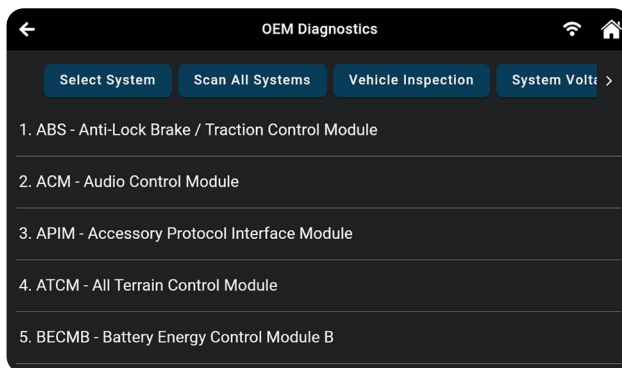

- **Select System:** Perform a scan for each system group, such as **Powertrain**, **Body**, or **Chassis**. This approach saves time compared to scanning all systems, as the tablet scans only one system group at a time. [See page 41]
- **Scan All Systems:** Perform a comprehensive scan of all available network modules. While this process may take some time, it provides thorough and complete information about all the vehicle's systems. [See page 41]
- **Vehicle Inspection:** Perform a complete vehicle health status report, including: OBD II check, all network system scan, service check, warning lights, tire pressures, and more. [See page 50]
- **System Voltages:** Perform a voltage test to check ECU power, ground, and communication line health (e.g., CAN_H, CAN_L). This check helps identify wiring or network issues affecting ECU performance. [See page 54]
- **Custom Scan:** Perform a scan on selected systems only. This saves time by allowing you to target specific systems instead of scanning all systems. [See page 55]
- Tap the “**individual**” listed control module name to perform a diagnostic check on that single module. [See page 44]

SELECT SYSTEM & SCAN ALL SYSTEMS

SCANNING THE SELECT SYSTEM & SCAN ALL SYSTEMS

- From the OEM Diagnostics results screen, choose one of the following.
 - **Select System** – To scan individual modules (Powertrain, Chassis, or Body).
 - **Scan All Systems** – To scan all available modules automatically.
 - On *BMW models only*, follow these additional steps:
 - Turn the ignition OFF, then back ON.
 - Tap **Continue** to complete the scan.
- The system list displays a “Scanning...” message for the module being scanned.
 - Scanned modules will display their results immediately.
 - The system list scrolls automatically to keep the scanning module visible.
 - Tap **Cancel** to stop the scan and display results for completed systems.

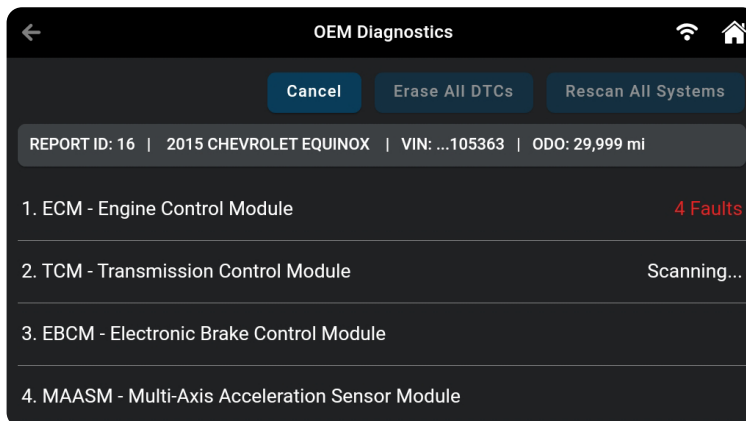

- Once the scan is completed, the system will display results and enable the **Erase All DTCs** and **Rescan All Systems** buttons.
 - If the Tablet fails to link to the vehicle's computer, a “Scan Failed” message displays.
 - Ensure the vehicle is OBD II compliant.
 - Verify the connection at the DLC, and verify the ignition is ON.
 - Turn the ignition OFF, wait 5 seconds, then back ON to reset the computer.
 - Tap **Try Again** to try again; or tap **Cancel** to return to the Home screen.
- The screen displays the diagnostic test results.

VIEWING THE TEST RESULTS

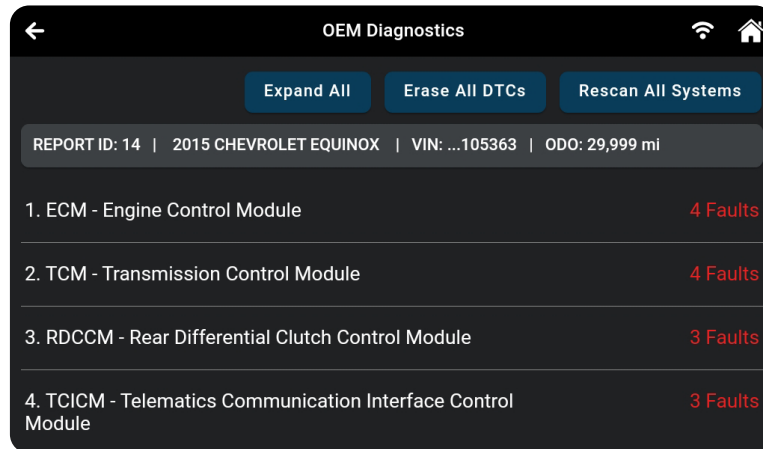

Scan results are shown immediately following completion of a scan; and can also be viewed later using the **PREVIOUS VEHICLES** function available through the Home screen. [\[See page 104\]](#)

Each report begins with a vehicle information bar that includes a **Report ID**, the vehicle's description (**year/make/model**), the last six digits of the Vehicle Identification Number (**VIN**) and the odometer reading (**ODO**) at the time the scan was performed.

The results window lists all tested Control Modules with the corresponding result:

- **# Fault** – Indicates the number of reported DTCs.
- **No Fault** – Indicates that no DTCs were retrieved.
- **Available** – Indicates that the module is part of the system but does not report DTCs.
- **No Response/Not Equipped** – Indicates that the module is not supported.

The results screen also lets you:

- Tap **Expand All** to show the DTC details for all modules.

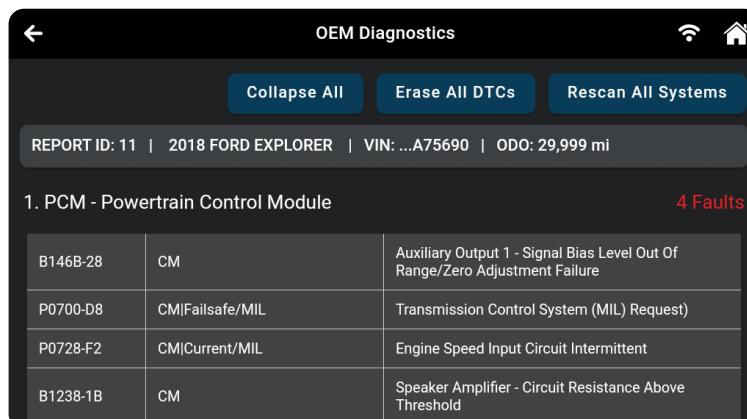

- Tap **Collapse All** to hide the DTC details and return to the summary view.

Navigating the Results Screen:

- Tapping a **module name** opens the Available Functions menu for that module.

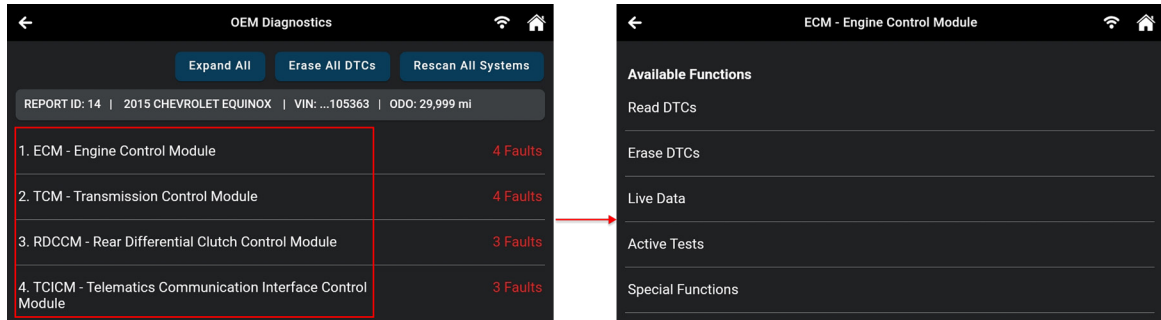

- Tapping the **Faults** count for a module opens the DTC Information screen showing all retrieved DTCs for that module.

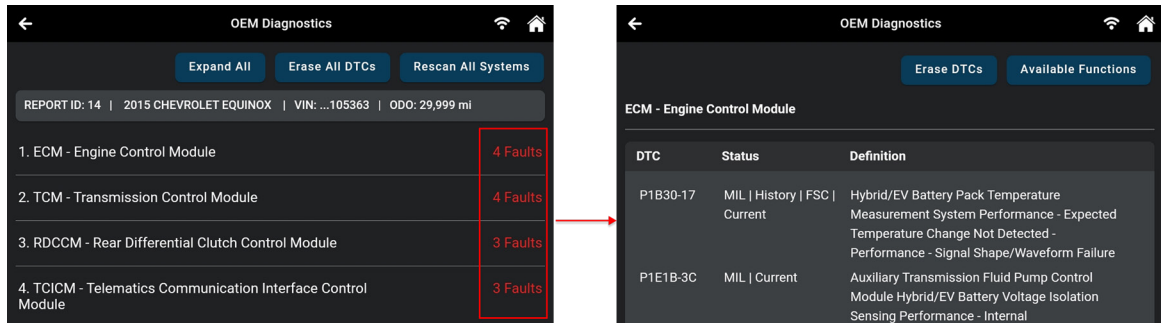

ERASE ALL OEM DTCs

Erase all the stored OEM DTCs from the vehicle's computer memory as follows:

1. Tap the **Erase All DTCs** button at the top of the *Select System* or *Scan All Systems* results page.
 - Ensure that the ignition is in the Key ON, Engine OFF position.
 - The tablet displays an attention message confirming deletion.
 - If you want to proceed, tap **Continue**.
 - If you do not want to proceed, choose **Cancel** to exit the erase procedure.
2. By selecting to Erase DTCs, a “*One moment please...*” progress dialog displays during the erase process.
 - If the erase was successful, a “confirmation” dialog displays.
3. If the erase was not successful, an “advisory” dialog displays with instructions to either:
 - “*Turn the ignition off, then turn the ignition on*” = follow steps and tap **Erase DTCs** to resume.
 - “*Erase has failed*” = tap **Erase Again** to try again.
4. Once all DTCs are erased, tap **Scan Again** to confirm that all DTCs were erased, or, tap **Close** to exit.

RESCAN ALL SYSTEMS

Use this function to get the most current diagnostic status for the vehicle under test – particularly as you continue to troubleshoot each individual control module.

1. From the “*Select System*” or “*Scan All Systems*” result page, tap the **Rescan All Systems** button at the top right of the page.
2. The tablet generates a new report and updates the “*Select System*” or “*Scan All Systems*” results page. [[See page 42](#)]

VIEWING & SCANNING AN INDIVIDUAL CONTROL MODULE

Perform diagnostics for a single, selected vehicle module. Depending on the module selected, you can **Read DTCs**, **Erase DTCs**, view **Live Data**, perform **Active Tests**, **Special Functions** procedures, and **ECU Information**.

1. Tap the name of the module you wish to explore further from the *OEM Diagnostics* screen, the *Select System* results page, or the *Scan All Systems* results page.

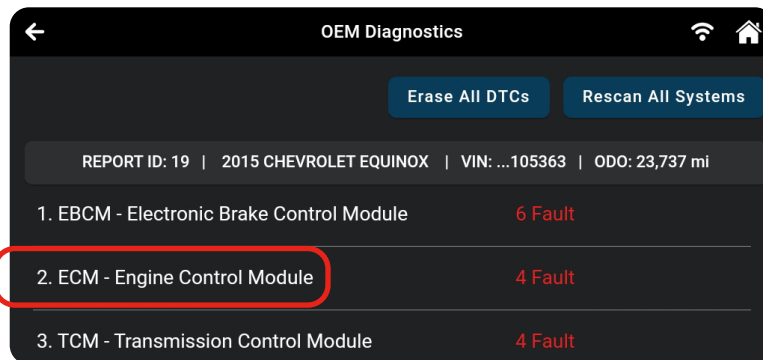

2. The *Available Functions* selection screen displays.

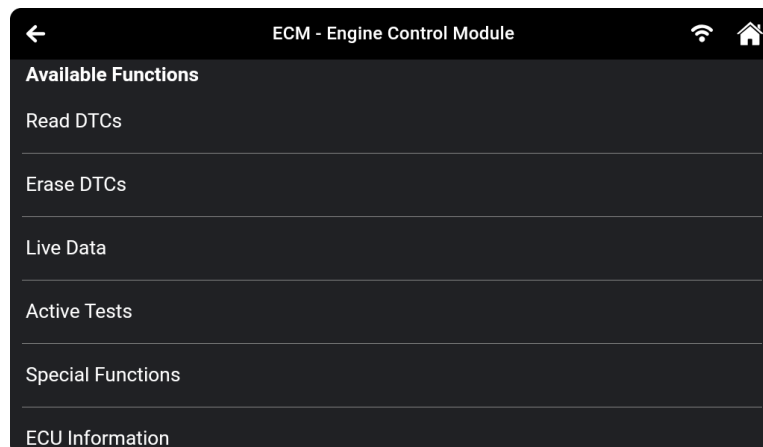

3. Tap the corresponding button to perform the function you would like to run, or, tap **Back** to exit.



NOTE: Actions that are not available for the selected module are “grayed” out.

- **Read DTCs** – [[See page 45](#)]
- **Erase DTCs** – [[See page 46](#)]
- **Live Data** – [[See page 46](#)]
- **Active Tests** – [[See page 48](#)]
- **Special Functions** – [[See page 48](#)]
- **ECU Information** – [[See page 49](#)]

READING DTCs FOR A SELECTED MODULE

1. Tap **Read DTCs** in the “Available Functions” menu.
 - The tablet retrieves and displays DTCs stored in the vehicle’s computer for the currently selected module.
 - Each entry shows the DTC number, type (status), and definition.

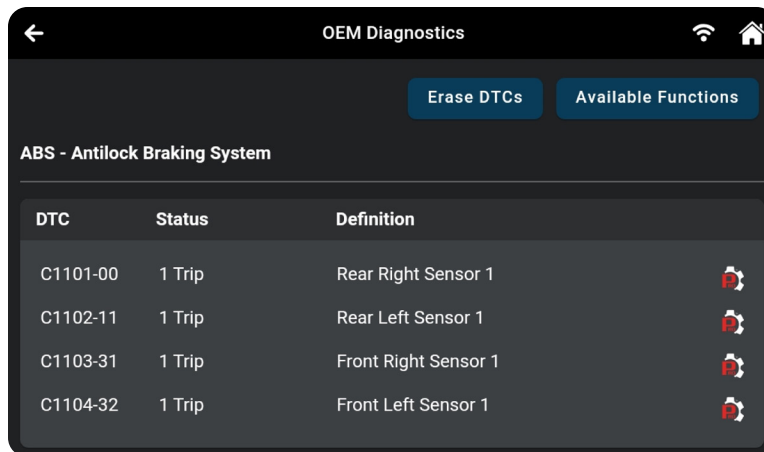

NOTE: If no DTCs for the selected module are currently stored in the vehicle’s computer, the message “No DTCs” displays.

2. Continue as desired:
 - Tap the **Erase DTCs** button to erase ALL retrieved Diagnostic Trouble Codes (DTCs).
 - Tap the **Available Functions** button to open its selection menu.
 - Tap the **RSPRO icon** (if it is displayed) to view the Most Likely Component/System Cause for DTC.



NOTE: The tablet currently supports the Fix for DTC function for ABS and SRS modules.

- Tap the ← icon at the top left of the screen to return to the *Available Functions* screen.

ERASING DTCs FOR A SELECTED MODULE

1. Tap **Erase DTCs** in the “Available Functions” menu. A “confirmation” message displays.
 - Ensure that the ignition is in the Key ON, Engine OFF position.
 - If you are sure you want to proceed, tap **Continue**.
 - If you do not want to proceed, tap **Cancel** to cancel the erase procedure.
2. If you chose to erase DTCs, an “Erasing DTCs...” message displays while the erase function is in progress.
 - If the erase was successful, a “confirmation” message displays. Tap **Scan Again** to re-scan the currently selected module; or tap **Close** to exit and return to the test results screen.
 - If the erase was not successful, an “advisory” message displays. Make sure the tablet is properly connected to the vehicle’s DLC, then tap **Try Again** to repeat the erase procedure.
 - Tap **Cancel** to cancel the erase procedure and close the message.

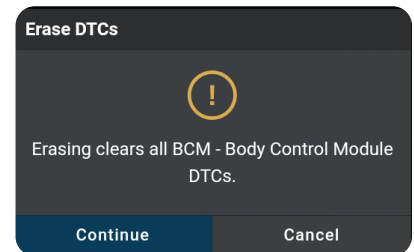

VIEWING LIVE DATA FOR A SELECTED MODULE

Live Data PID Groups

The tablet supports the Live Data PID Groups function for ECM/PCM and TCM systems. This feature allows you to view vehicle data more easily by organizing related parameters (PIDs) into categorized groups.

1. Tap **Live Data** in the “Available Functions” menu to place the tablet in Live Data mode.
2. The Live Data menu screen displays.

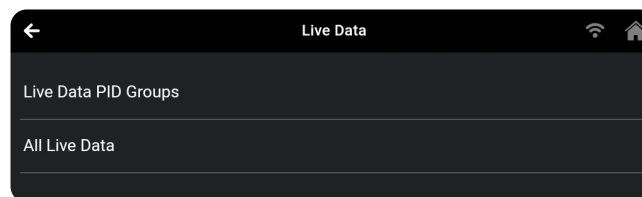

3. Tap **Live Data PID Groups**.

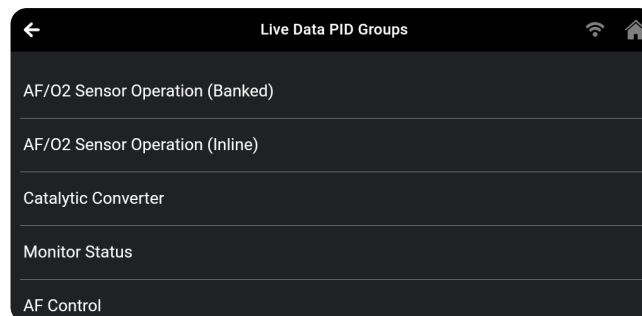

- The tablet displays a list of available data groups provided by the system.
- Tap the group for which you wish to view the Live Data.

- The system will automatically scan and display all available PIDs.

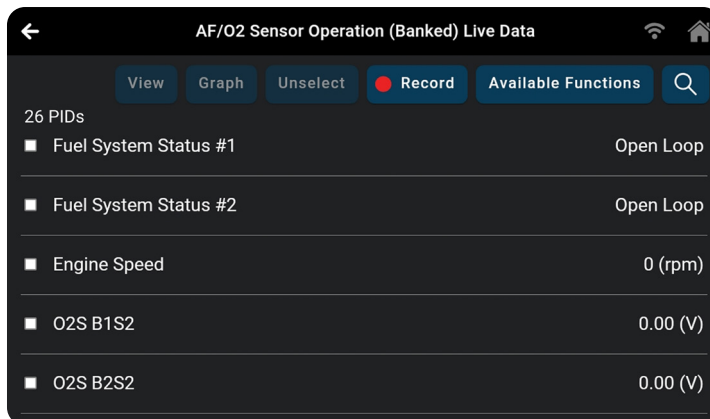

All Live Data

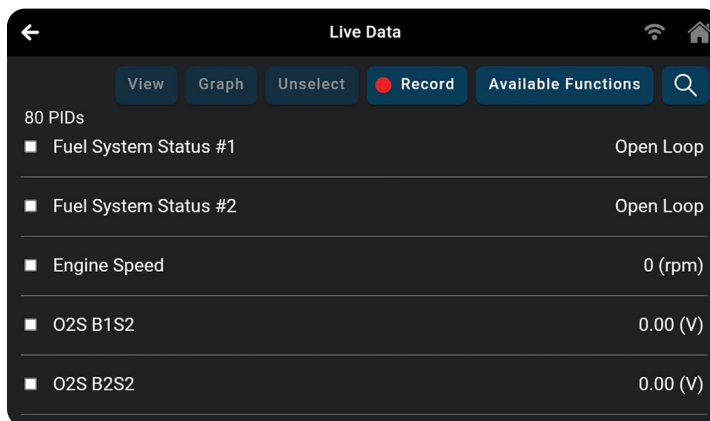

- Tap **Live Data** in the “Available Functions” menu to place the tablet in Live Data mode.
 - For ECM/PCM and TCM systems, select **All Live Data** from the Live Data menu.
- The system will automatically scan and display all available PIDs.



- Select the PIDs you wish to explore further and continue as desired:
 - Tap the **View** button to view PID data in a tabular format.
 - Tap the **Graph** button to view PID data in graphical format.
 - Tap the **Unselect** button to unselect all PID parameters.
 - Tap **Record** to record the selected Live Data PID(s) in real time.



NOTE: Tapping the **Record** button without selecting any PIDs will record **all** of the vehicle's available PIDs.

- Tap the **Available Functions** button to open its selection menu.
- Tap the  icon to quickly search and select desired PID(s).
- Tap the  icon at the top left of the screen to return to the *Available Functions* screen.

PERFORMING ACTIVE TESTS FOR A SELECTED MODULE

Active Tests let you perform active tests for various vehicle actuators and systems. The specific tests available depend on the vehicle make and model.

1. Tap **Active Tests** in the “Available Functions” menu.
 - The tablet retrieves and displays a menu of Active Tests available for the vehicle under test.

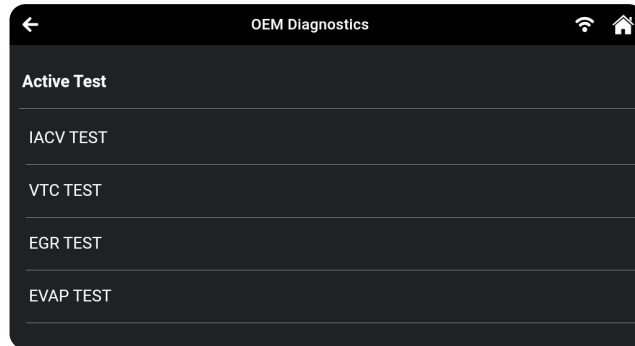

NOTE: If Active Tests are not supported for the vehicle under test, the message “Active Test is not supported for this vehicle” displays. Tap **Exit** to return to the previous page.

- Choose the desired test.
- The tablet may display one or more instructional screens to prepare the vehicle for testing.

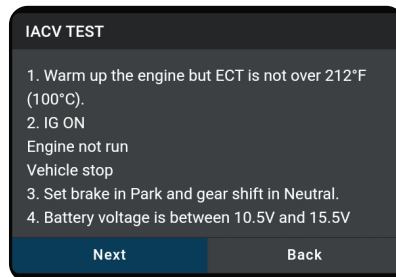

2. Prepare the vehicle for testing, as necessary.
 - The tablet displays a “control” screen to run the test.
3. Tap the appropriate control to operate the actuator as desired.
 - The screen refreshes to show the result.
4. Repeat step 3 as desired.
5. Tap **Back** to return to the Active Test menu.

PERFORMING SPECIAL FUNCTIONS FOR A SELECTED MODULE

Special Functions let you perform diagnostic and calibration procedures for various vehicle actuators and systems. The specific tests available depend on the vehicle make and model.

1. Tap **Special Functions** in the “Available Functions” menu.
 - The tablet retrieves and displays one or more menus of Special Functions available for the vehicle under test.

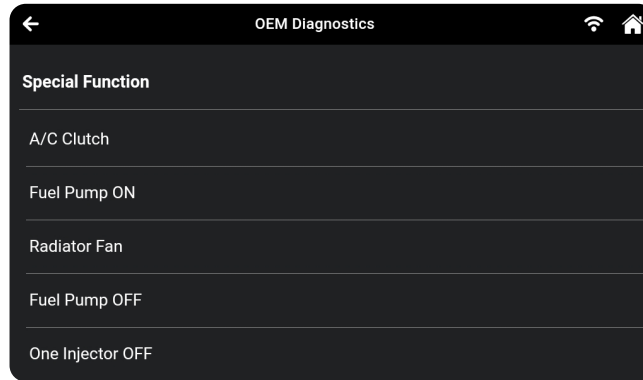

NOTE: If Special Functions are not supported for the vehicle under test, the message “Special Function is not supported for this vehicle” displays. Tap **Exit** to return to the previous page.

2. Make the necessary selections to choose the desired test.
 - A series of instructional screens display.

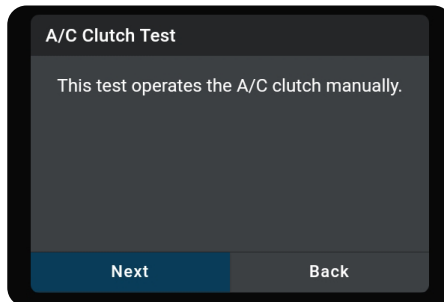

3. Follow the on-screen prompts to prepare the vehicle for testing, and to perform the selected test procedure.
 - A “results” screen displays when the test procedure has completed.
4. Tap **Finish** or **Exit** to return to the previous menu.
5. Tap the ← icon at the top left of the screen to return to previous page.

VIEWING ECU INFORMATION FOR A SELECTED MODULE

This function retrieves and displays the specific information for the tested control unit, including Protocol, ECU ID, version number and other specifications.

1. Tap **ECU Information** in the “Available Functions” menu.
 - The tablet retrieves and displays the ECU Information for the selected module.

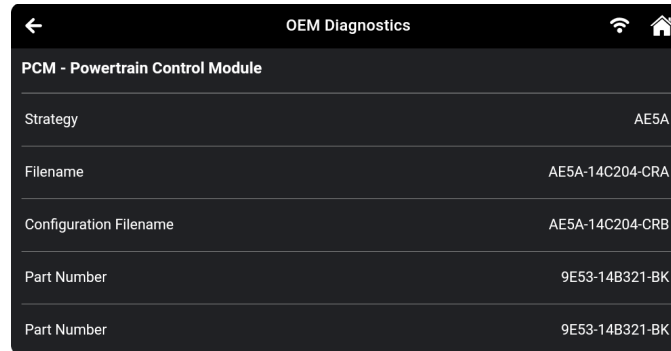

2. Tap the ← icon at the top left of the screen to return to previous page.

VEHICLE INSPECTION HEALTH REPORT

The **Vehicle Inspection** function facilitates assessment of a vehicle's systems and components to determine its overall health and to identify potential issues. Four types of Vehicle Inspection reports are available: **Diagnostic Report**, **Customer Report**, **Collision Industry Report**, and **Digital Vehicle Report**. Each report returns a unique set of data according to the report type.

Use the Vehicle Inspection function to retrieve and view operational and diagnostic information including OBD II Diagnostic Info, MIL DTC Diagnostic Info, Scan All Systems, Service Check, Service Warning Lights, TSBs & Recall, Scheduled Maintenance, and Predictive Failure.

1. From the OEM Diagnostics screen, tap the **Vehicle Inspection** button.
 - The Vehicle Inspection screen displays.
2. Select the type of report you wish to perform.
 - **Diagnostic Report** - Provides a report for OBD II data, MIL DTC additional information, Scan All Systems data, and Vehicle Care.
 - **Customer Report** - Provides a report for OBD II data, Scan All Systems data, Service Check, Service Warning Lights, and Vehicle Care.
 - **Collision Industry Report** - Provides a report for OBD II data, Scan All Systems data, Service Check, and Service Warning Lights.
 - **Digital Vehicle Report** - Allows technicians to create structured inspection reports, capture findings with images/videos, and share professional digital reports with customers.

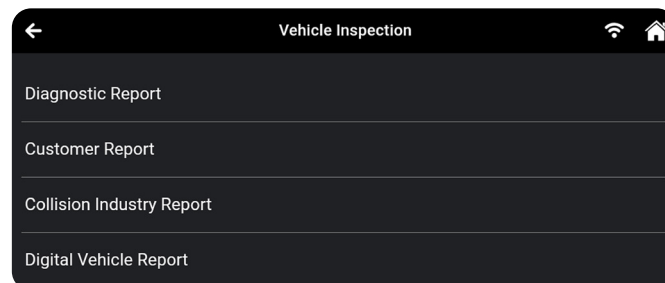

FOR DIAGNOSTIC REPORT, CUSTOMER REPORT, AND COLLISION INDUSTRY REPORT

1. From the Vehicle Inspection menu, tap the report type you wish to view.
2. The next screen displays the report type menu.
 - **PreScan** - View the vehicle's diagnostic report before making any repairs.
 - **PostScan** - View the vehicle's diagnostic report after completing the repairs or improvements.



NOTE: You must conduct te PreScan report before generating the PostScan report.

3. A progress bar displays a “Retrieving Vehicle Information...” message while the tablet scans all of the vehicle's equipped modules.
 - The report can take several minutes to complete depending on the number of systems available on the vehicle being tested. Tap **Cancel** to abort the scan.

Viewing The Test Results

Scan results are shown immediately following completion of a scan; and can also be viewed later using the **PREVIOUS VEHICLE** function available through the **Menu** or **Home** screen. [\[See page 104\]](#)

Each report begins with a vehicle information tab that includes a **Report ID**, the vehicle's description (**year/make/model**), the last six digits of the Vehicle Identification Number (**VIN**) and the odometer reading (**ODO**) at the time the scan was performed.

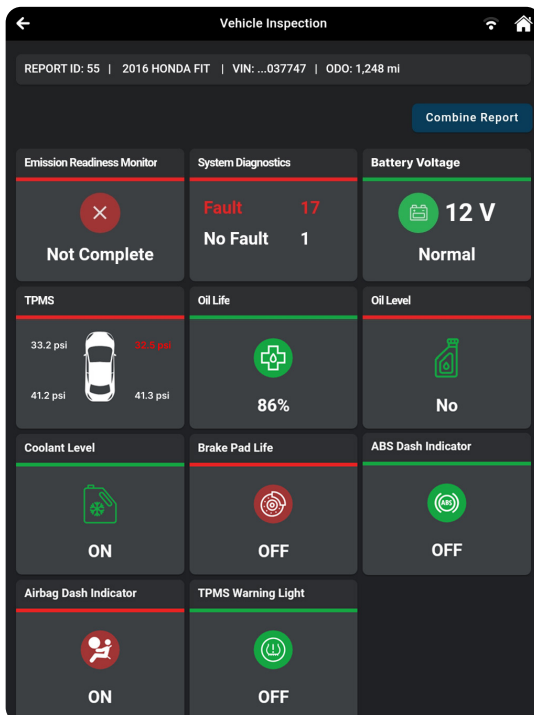

Figure 3: OBID II Diagnostics section is enabled

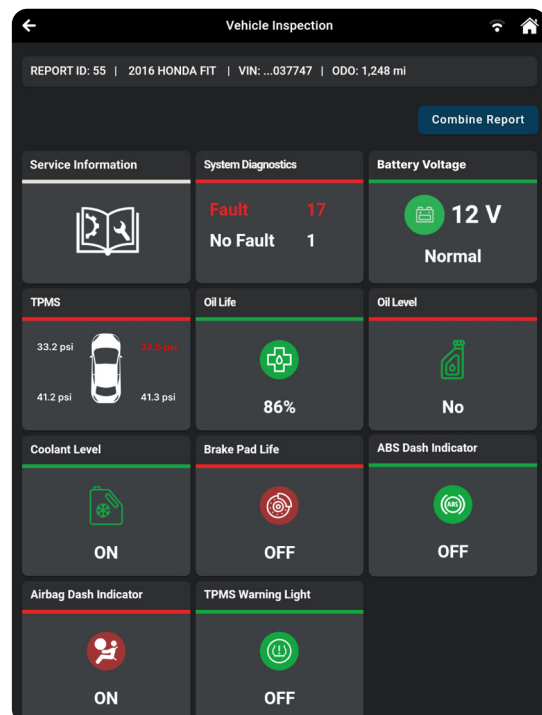

Figure 4: OBID II Diagnostics section is disabled

Emissions Readiness Monitors Status

Indicates whether the vehicle is ready for an Emissions Test (Smog Check) based on DTCs present, Freeze Frame data, Monitor Status, MIL (Check Engine Light) status, State/Region, and Engine Type. Results are shown as “Complete” or “Not Complete”.

- Tap the **Emission Readiness Monitor** tab to view the OBD II Diagnostics report [[See page 17](#)].
- **Emission Readiness Monitor** - For a “Not Complete” result, drive cycle procedures can be found in the OBD II Diagnostics screen. [[See page 30](#)]

Service Information

Displays TSBs and Recalls, Scheduled Maintenance, and Predicted Failures if the OBD II Diagnostics section is disabled in the Vehicle Inspection Setup. [[See page 110](#)]

- Tap the **Service Information** tab to view the additional information. [[See page 39](#)]

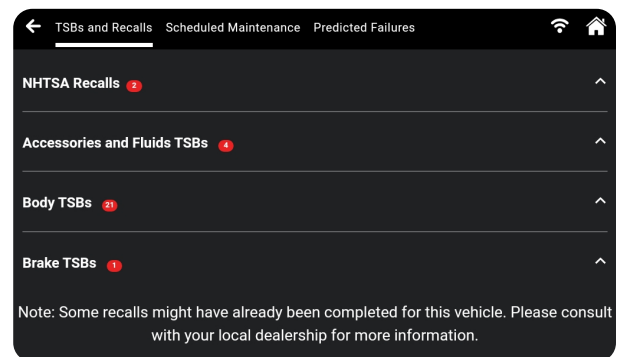

System Diagnostics (DTC Status Overview)

Gives a quick snapshot of all Diagnostic Trouble Codes (DTCs) found on the vehicle with “Fault – DTCs reported” or “No Fault – no DTCs present”.

- Tap the **System Diagnostics** tab to open the Scan All Systems window to view scan details. [[See page 41](#)]

Vehicle Service Status

Some vehicles are capable of checking and reporting on its various service items. If available, the tablet displays these as individual tab segments as defined below. Use these results to share with customer or to create a service due task list.

- **Battery Voltage:** Indicates the current battery charge voltage and suggests if the battery requires replacement. The Battery Voltage field is color-coded to provide a visual indication of battery status: *Green = good; Yellow = poor; Red = replace battery*.
 - Tap the **Battery Voltage** tab to access the Battery/Alternator Test. [[See page 83](#)]
- **TPMS / Tire Pressure Readings:** Shows the status of the vehicle’s Tire Pressure Monitoring System (TPMS) and the individual tire pressures for all vehicle tires. The TPMS field is color-coded to provide a visual indication of tire pressure status: *Green = good; Red = low pressure*.
- **Oil Life:** Shows the current oil life for the vehicle’s lubricating oil as a percentage of 100. The Oil Life field is color-coded to provide a visual indication of oil life status: *Green = good; Red = poor*.
- **Oil Level:** Shows if the level is normal or below the manufacturer’s set threshold: *Green = Good; Red = Low Level Warning*.

- **Coolant Level:** Indicates if the coolant reservoir is filled to the manufacturer's recommended specifications. The Coolant Level is color-coded and provides a visual status: *Green = OK; Red = Low.*
- **Brake Pad Life – Front & Rear:** Shows the current measured brake pad life for the Front and Rear axle as a percentage of 100. The Brake Pad Life is color-coded and provides a visual status: *Green = OK; Red = Not OK.*

Dashboard Warning Light Status

The tablet can read if the vehicle's systems are reporting a dashboard warning light status. If available for the vehicle under test, the tablet displays these as individual tab segments as defined below. Use these as part of the inspection process to confirm an illuminated dashboard warning light.

- **Airbag Dash Indicator:** Reports if the airbag dashboard light is currently ON or OFF. It is color-coded to provide a quick visual status: *Red = ON; Green = OFF.*
- **TPMS Warning Light:** Reports if the Tire Pressure Monitoring System (TPMS) dashboard light is currently ON or OFF. It is color-coded to provide a quick visual status: *Red = ON; Green = OFF.*
- **ABS Dash Indicator:** Reports if the Anti-Lock Braking System (ABS) dashboard light is currently ON or OFF. It is color-coded to provide a quick visual status: *Red = ON; Green = OFF.*

Pre/PostScan Report

The Pre/PostScan Report is a crucial part of maintenance process, serving as a strategic guidepost for effective system upkeep. It consists of two key phases: **PreScan**, conducted before any work begins, and **PostScan**, performed after repairs or improvements are completed. By offering a comparative analysis of these two reports, it provides a comprehensive understanding of the system's development, ensuring transparency, and operational excellence.

- From the PostScan report, tap the **Combine Report** button to perform the function.

System	PreScan	PostScan
Emission Inspection Status	Fail	Pass
Battery Voltage	12.19 V	12.21 V
Service Check		
Oil Life	90 %	90 %
Oil Level	Low	OK
Brake Pad Life	OFF	OFF
TPMS		
Left Front Tire Pressure	33.2 psi	33.2 psi
Left Rear Tire Pressure	41.3 psi	41.3 psi

FOR DIGITAL VEHICLE REPORT

Digital Vehicle Inspection (DVI) is a powerful feature designed to streamline and fully digitize the entire vehicle inspection process. This function enables technicians to:

- Create structured inspection reports complete with detailed checklists.
- Capture and attach visual images/videos of vehicle conditions.
- Comprehensively document all inspection findings (e.g., worn brake pads, fluid leaks).
- Share professional reports digitally with customers.

1. From the Vehicle Inspection menu, tap **Digital Vehicle Report**.

- A “*One moment please...*” message displays while function is in process.

2. After processing is completed, the Digital Vehicle Inspection screen displays.

- This screen presents a detailed inspection checklist organized by categories, showing various Components and a Comments column.

Service Type	Components	Comments
General Inspection		
None	Battery	SOC <input type="text"/>
None	Battery Terminals	<input type="checkbox"/> Corroded
None	Battery Hold Down/Tray	<input type="checkbox"/> Missing
None	Windshield Wipers	<input type="checkbox"/> Streaking <input type="checkbox"/> Torn <input type="checkbox"/> Missing
None	Windshield Washer Pump	<input type="checkbox"/> Inoperative

3. Perform the inspection and fill in the report details:

- **Select Service Type:** For each component, tap the dropdown menu (defaulting to “None”) to select the appropriate service status or recommendation (e.g., Satisfactory, Marginal, Replace).

- **Record Comments:**

- Mark the relevant checkboxes to indicate specific conditions (e.g., “Corroded” for Battery Terminals, “Streaking” for Windshield Wipers).
- For free-form text notes (e.g., “SOC” for Battery), tap the **text field** and enter your observations.

- **Attach Images/Videos:** Tap the camera icon at the end of each component row to capture and attach images or videos related to the component's condition. This provides visual evidence for your findings.

4. Once you have completed the inspection and entered all necessary information, tap **Save Report** to save the report.

5. The report can be viewed later using the **PREVIOUS VEHICLE** function available through the **Menu** or **Home** screen. [\[See page 104\]](#)

SYSTEM VOLTAGES

1. From the OEM Diagnostics results screen, tap **System Voltages**.

- The System Voltage menu displays.

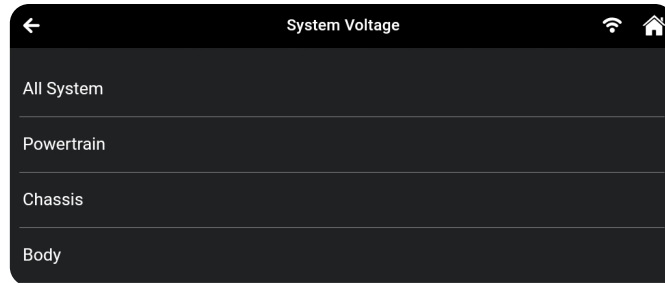

2. Choose the modules that you wish to scan, either **All System**, **Powertrain**, **Chassis** or **Body**.
 - The system list displays a "Linking..." message for the module being scanned.
 - Scanned modules will display their results immediately.
 - The system list scrolls automatically to keep the currently scanning module visible.
 - Tap **Cancel** to stop the scan and display results for completed systems.
 - Once the scan is complete, the system will display results and enable the **Rescan All Systems** button. The **Cancel** button will be disabled.
 - If the Tablet fails to link to the vehicle's computer, a "Scan Failed" message displays.
 - Ensure the vehicle is OBD II compliant.
 - Verify the connection at the DLC, and verify the ignition is ON.
 - Turn the ignition OFF, wait 5 seconds, then back ON to reset the computer.
 - Tap **Try Again** to try again; or tap **Cancel** to return to the Home screen.
3. The System Voltages screen will display the diagnostic test results.

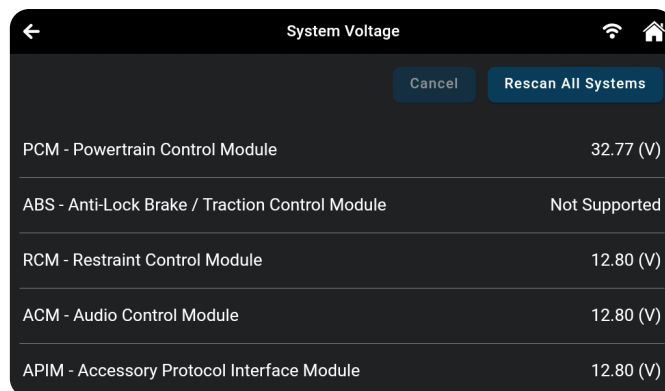

CUSTOM SCAN

1. From the OEM Diagnostics results screen, tap **Custom Scan**.
 - The Custom Scan screen displays.

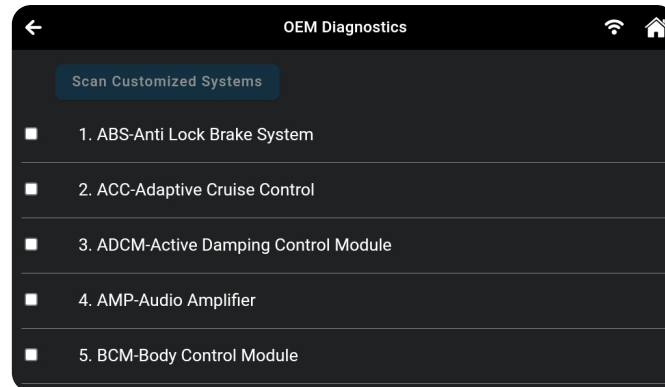

2. Use the checkboxes to choose the modules that you wish to scan, then tap **Scan Customized Systems**.
3. The system list displays a “Scanning...” message for the module being scanned.
 - Scanned modules will display their results immediately.
 - The system list scrolls automatically to keep the scanning module visible.
 - Tap **Cancel** to stop the scan and display results for completed systems.

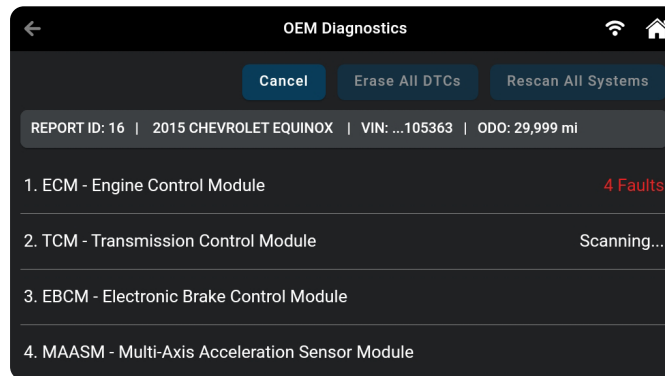

4. Once the scan is completed, the system will display results and enable the **Erase All DTCs** and **Rescan All Systems** buttons.
 - If the Tablet fails to link to the vehicle’s computer, a “Scan Failed” message displays.
 - Ensure the vehicle is OBD II compliant.
 - Verify the connection at the DLC, and verify the ignition is ON.
 - Turn the ignition OFF, wait 5 seconds, then back ON to reset the computer.
 - Tap **Try Again** to try again; or tap **Cancel** to return to the Home screen.
5. The screen displays the diagnostic test results. Refer to the Select System or Scan All Systems test results screen. [\[See page 42\]](#)

FCA & NISSAN SECURE GATEWAY ACCESS

Innova has partnered with FCA, Nissan and AutoAuth® to grant authentic access to FCA & Nissan Secure Gateway (SGW). Our partnership allows us to offer SGW-unlocking solutions. This feature applies only to FCA (Chrysler, Dodge, Jeep, RAM, etc.) vehicles manufactured after 2018 and certain Nissan vehicles manufactured after 2020.

WHAT IS SGW?

Starting with 2018 models, a Secure Gateway Module (SGW) was implemented in the electrical architecture to secure the vehicle's network and control access. This module is similar to a firewall that prevents unauthorized vehicle network access, which may put vehicle systems and customers at risk.

FUNCTIONS LIMITED BY SGW

Certain functions are restricted due to SGW implementation:

- Erase OEM DTCs (FCA vehicles only)
- OEM Active Testss / Special Functions
- Workshop Tools (Resets, Relearns, Routines, Calibrations)

However, you can still carry out the following:

- OBD II Diagnostics
- Reading OEM DTCs
- Viewing OEM Live Data
- Erase OEM DTCs (Nissan vehicles only)

PREPARING THE TABLET FOR SGW ACCESS

1. Make sure your tablet is up-to-date by installing the latest firmware. [[See page 117](#)]
 2. Register for an authorized [AutoAuth®](#) account.
 - Click **Register** to create your account.
 - Fill in the necessary '*User Signup*' fields and agree to the AutoAuth Terms & Conditions.
 - Click the **Sign-Up** button.
 - Check your email for account verification.
 - Follow the steps to sign up as a **Service Center** or as an **Independent Technician**.
 3. Register your device.
 - Tap **Settings** to view and copy your tablet's serial number. [[See page 108](#)]
 - On your AutoAuth account, navigate to **Manage Tools** and select **Add Tool**.
 - Select "**Innova Electronics**" as the manufacturer.
-

- Under model, select “**All Models**”.
- Enter, or paste, your tablet’s serial number.



NOTE: Be cautious with the number ‘0’ and the letter ‘O.’ Both can look quite similar.

- Click **Add Tool** to complete the process.
4. Your tablet is SGW-ready!

UNLOCKING THE SGW

Follow these steps when working on an FCA or Nissan vehicle with a secure gateway.

1. Ensure you have a stable and constant Internet connection. [[See page 112](#)]
2. Perform the desired function, such as erase OEM DTCs, Active Tests, Special Functions, or Workshop Tools.
 - A login window displays.
3. Enter your AutoAuth login credentials and tap **Continue**.
4. Proceed as usual to complete your diagnosis.

WORKSHOP TOOLS

The **WORKSHOP TOOLS** tab allows you to perform over 40 OEM service reset procedures. Depending on the vehicle being tested, the tablet will only display the procedures which are specific to the vehicle. This can include a combination from any of the following reset procedures.



NOTE: Tap the **i** icon to access the video tutorial and description for each function.

AVAILABLE FUNCTIONS

- Resets:** Provides services to restore settings and parameters to their default state. [\[See page 61\]](#)

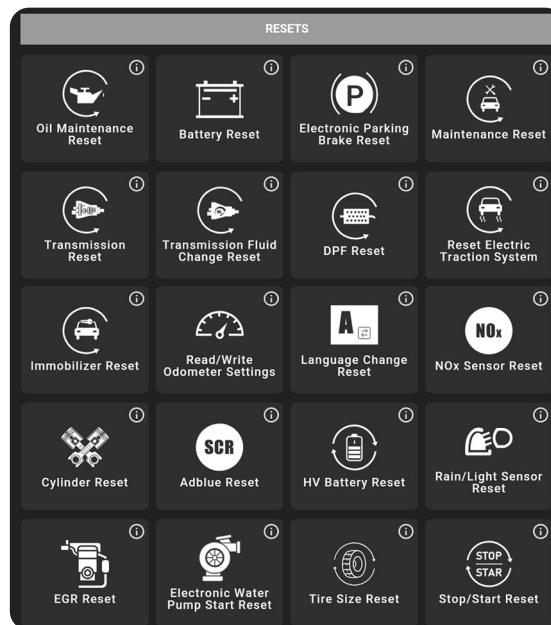

- Relearns:** Provides services to update and adjust system parameters to synchronize with changes or repairs. [\[See page 79\]](#)

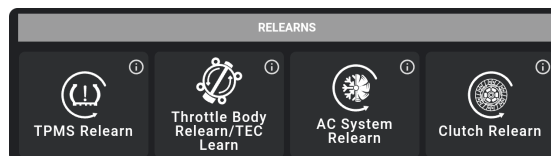

- Routines:** Provides services to execute routine maintenance processes and frequent tasks to maintain system performance. [\[See page 83\]](#)

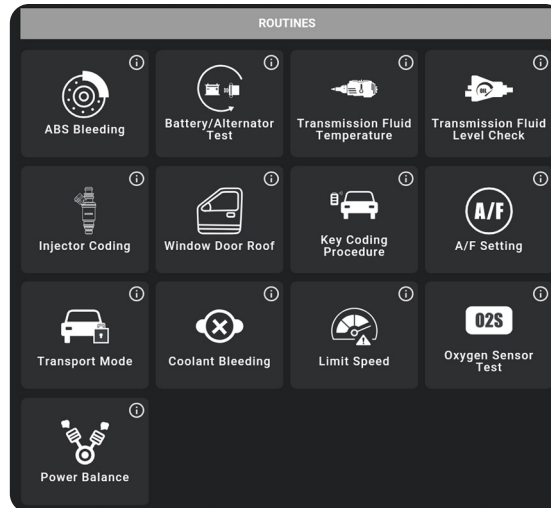

4. **Calibrations:** Provides services to calibrate sensors and equipment to ensure accuracy and reliability of data. [\[See page 97\]](#)

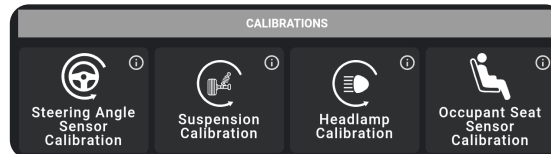

5. **Configurations:** Provides services to configure and manage vehicle and ECU settings to ensure correct system operation. [\[See page 101\]](#)

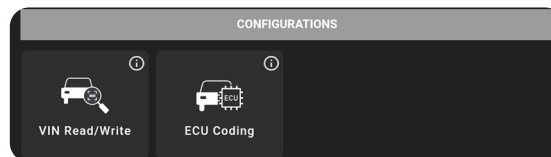

6. **Inspections:** Conducts a comprehensive vehicle inspection and system voltages scan. [\[See page 40\]](#)

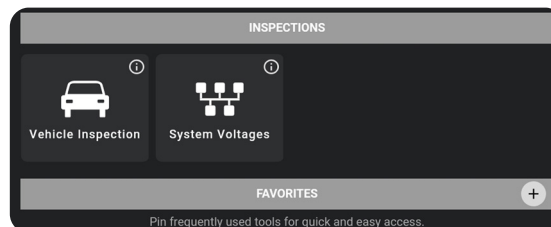

7. **Favorites Function:** Quickly access your favorite Workshop Tool functions by pinning them to the top of the screen. [\[See page 103\]](#)

RESETS

OIL MAINTENANCE RESET

This function resets the Oil Maintenance Light.



NOTE: The function procedures vary between vehicle makes and models.

1. Tap **Oil Maintenance Reset** on the Workshop Tools screen.
 - An “instructional” dialog displays to confirm selection.
 - Select **Yes** to continue, or **No** to cancel.
 - A “One moment” message displays while the procedure is in process.
2. When the reset process has completed, a “confirmation” message displays. Tap **Exit** to return to the Workshop Tools screen.
 - If the oil reset was not successful, an “advisory” message displays.

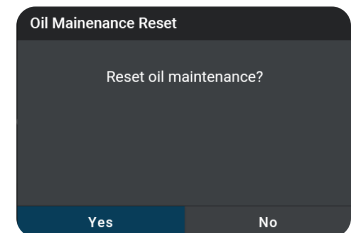

NOTE: If the tablet cannot reset the Oil Maintenance Light, an “instructional” dialog displays, showing the manual procedures for resetting the indicator light. When finished viewing the instructions, tap **Back** to return to the Workshop Tools screen.

BATTERY RESET

You can use the tablet to view the procedures for resetting the battery monitor system following battery replacement or perform battery reset OBD service.



NOTE: The function procedures vary between vehicle makes and models.

To view battery reset procedures:

1. Tap **Battery Reset** on the Workshop Tools screen.
 - The Battery Reset menu displays.
2. Tap **Battery Reset Procedures**.
 - The Battery Reset Procedures menu displays.
 - The menu provides access to **General Information**, **Battery Disconnection Precautions**, **Battery Connection Precautions**, and **Battery Connection Procedures**.

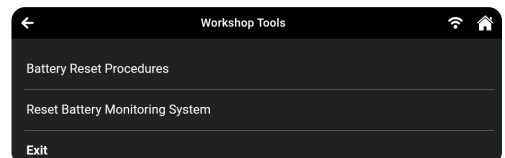

NOTE: If battery reset procedures are not available, an “advisory” message displays. Tap **Back** to return to the Workshop Tools screen.

3. Tap the information you wish to view.
 - The selected information displays.

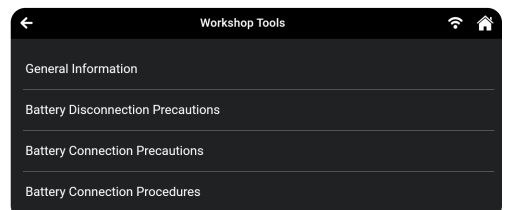

- When you have finished viewing the retrieved information, tap **Back** to return to the Battery Reset Procedures menu. Repeat **step 3** to view additional information.
 - When you have finished viewing all desired information, tap the **←** icon at the top of the page to return to the Workshop Tools screen.

To perform battery reset OBD service:

- Tap **Battery Reset** on the Workshop Tools screen.
 - The Battery Reset menu displays.
- Tap **Reset Battery Monitoring System** or **Battery Replacement Registration** (the available selection depends on the vehicle being serviced).
 - An “instructional” message displays.
- Follow the instructions provided to prepare the vehicle for battery reset OBD service. When all necessary procedures have been performed, tap **Next** to continue.
 - A “*One moment please...*” message displays while battery reset is in process.
- If the battery reset process is successful, a “Reset Complete” message displays. Tap **Exit** to return to the Workshop Tools screen.
 - If the battery reset process is not successful, a “Reset Fail” message displays. Tap **Exit** to return to the Workshop Tools screen.

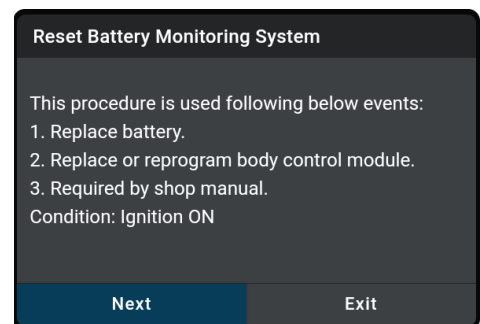
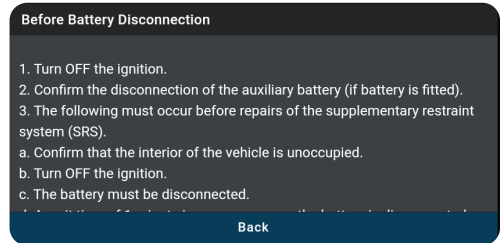

ELECTRONIC PARKING BRAKE (EPB) RESET

The **Electronic Parking Brake (EPB)** reset procedures vary between vehicle makes and models.

 **NOTE:** If an error occurs while performing calibration procedures, an “advisory” message displays. Tap **Exit** to return to the Workshop Tools screen.

- Tap **Electronic Parking Brake Reset** on the Workshop Tools screen.
 - For some vehicles, one or more sub-menus display. Tap the desired module and/or option, as appropriate. Proceed to **step 2**.

 **NOTE:** If Electronic Parking Brake reset is not supported by the vehicle under test, an “advisory” message displays. Tap **OK** to return to the Workshop Tools screen.

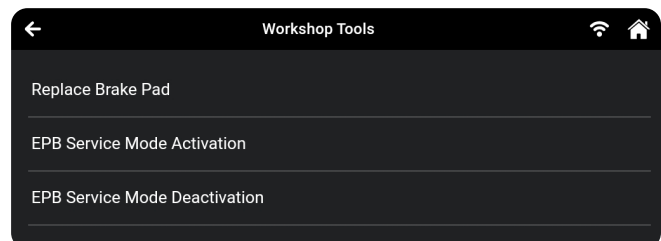

- A “One moment” message displays, followed by one or more “informational/instructional” or “selection” screens.
 - Perform reset procedures as directed. Tap **Next**, as appropriate, to continue to the next step.

- For some vehicles, “status” screens display as each phase of the reset procedure is successfully completed. Tap **Next**, as appropriate, to scroll to the next screen.

- A “One moment” message displays while the procedure is in process.
- A “results” screen displays when the reset procedure has completed.



NOTE: If the procedure is stopped due to a communication error, an “advisory” message displays. Tap **Exit** to return to the Workshop Tools screen.

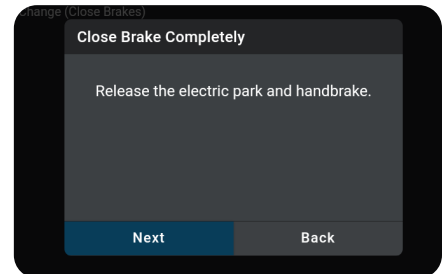

- Tap the ← icon at the top of the page to return to the Workshop Tools screen.

MAINTENANCE RESET

The Maintenance Reset function lets you view the procedures, or send a command, for resetting the scheduled maintenance counter to zero after servicing the vehicle.



NOTE: The function procedures vary between vehicle makes and models.

- Tap **Maintenance Reset** on the Workshop Tools screen.



NOTE: If Maintenance Reset is not supported by the vehicle under test, an “advisory” message displays. Tap **Exit** to return to the Workshop Tools screen.

- A “One moment please...” progress dialog displays. Tap **Cancel** to cancel the operation.

- Once ready, the Maintenance Reset menu displays.

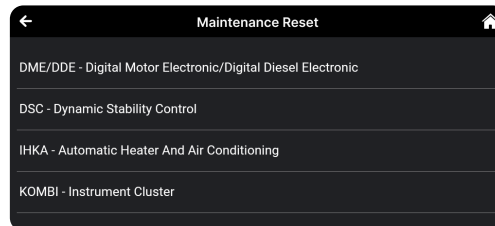

- Select the desired option, then perform the procedures as directed. Tap **Next**, as appropriate, to scroll to the next screen, or, tap **Exit** or **Cancel** to terminate the procedure.

- A “results” screen displays when the reset procedure has been completed. Tap **End** to terminate the procedure.

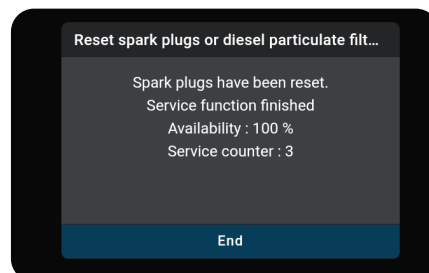

- Tap the ← icon at the top of the page to return to the Workshop Tools screen.

TRANSMISSION RESET

When replacing the Transmission Control Module (TCM) or the Hydraulic Control Unit (HCU), use this function to reset the vehicle's TCM and HCU values to their default values.



NOTE: The function procedures vary between vehicle makes and models.

1. Tap **Transmission Reset** on the Workshop Tools screen.



NOTE: If Transmission Reset is not supported by the vehicle under test, an "advisory" message displays. Tap **Exit** to return to the Workshop Tools screen.

- A "One moment please..." progress dialog displays. Tap **Cancel** to cancel the operation.
2. Once you select a module to perform Transmission Reset function, the Transmission Reset menu displays.

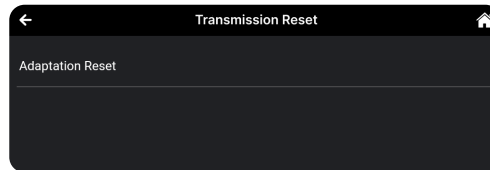

- Select the desired option, then perform the procedures as directed. Tap **Start** or **Continue**, as appropriate, to scroll to the next screen, or, tap **Exit** or **Cancel** to terminate the procedure.
3. A "results" screen displays when the reset procedure has been completed. Tap **End** to terminate the procedure.

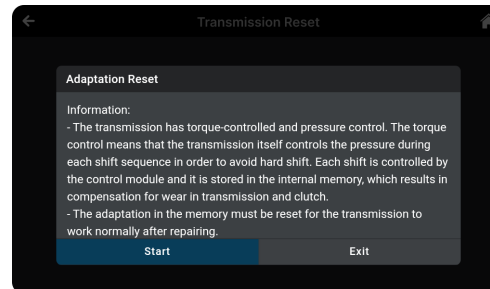

4. Tap the ← icon at the top of the page to return to the Workshop Tools screen.

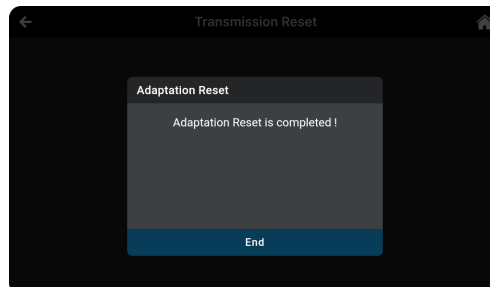

TRANSMISSION FLUID CHANGE RESET

Use the Transmission Fluid Change Reset function to reset deterioration data in the ECU following replacement of CVT transmission fluid.



NOTE: The function procedures vary between vehicle makes and models.

1. Select **Transmission Fluid Change Reset** on the Workshop Tools screen.



NOTE: If Transmission Fluid Change Reset is not supported by the vehicle under test, an “advisory” message displays. Tap **Exit** to return to the Workshop Tools screen.

- A “One moment please...” progress dialog displays. Tap **Cancel** to cancel the operation.
 - One or more sub-menus will display. Select the desired options, then proceed to **step 2**.
2. One or more “informational/instructional” screens display.

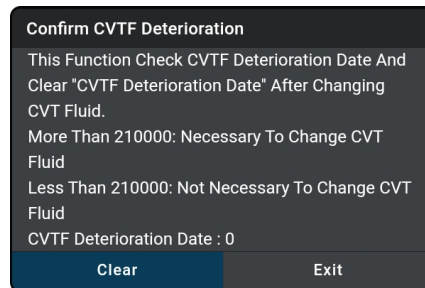

- Perform procedures as directed. Choose **Clear** or **Continue**, as appropriate, to scroll to the next screen.
3. For some vehicles, “status” screens display as each phase of the reset procedure is successfully completed. Choose **Next** or **Continue**, as appropriate, to scroll to the next screen.
 - A “results” screen displays when the procedure has been completed.

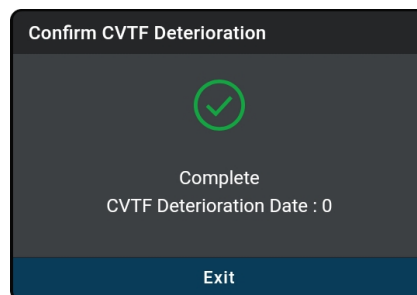

4. Tap **Exit** to close the results message.
5. Tap the ← icon at the top of the page to return to the Workshop Tools screen.

DPF RESET

Use this function to initialize regeneration of the vehicle's diesel particulate filter (DPF) to prevent it from causing damage because of accumulated soot and ash in the vehicle's exhaust system. This function also initializes the sensor and DPF component after they are replaced, when the DPF warning light is illuminated, or when replacing the DPF pressure sensor.



NOTE: The function procedures vary between vehicle makes and models.

1. Tap **DPF Reset** on the Workshop Tools screen.



NOTE: If DPF Reset is not supported by the vehicle under test, an "advisory" message displays. Tap **Exit** to return to the Workshop Tools screen.



NOTE: DPF Reset is performed on Diesel vehicles only.

- An "instructional" dialog displays to confirm selection. Select **Yes** to continue, or **No** to cancel.
 - A "One moment please..." progress dialog displays.
2. The DPF Reset menu displays. Select the desired option (see **step 3** or **step 5**, as appropriate).

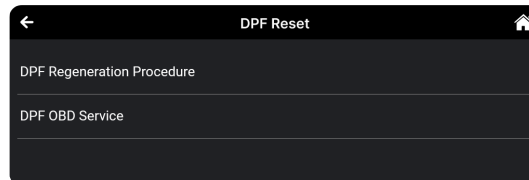

3. Tap **DPF Regeneration Procedure**.

- The DPF Regeneration Procedure screen displays.

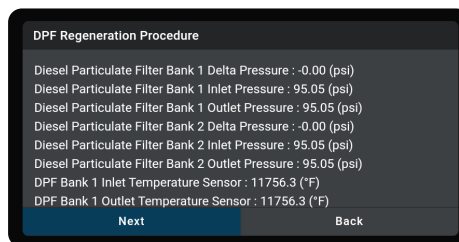

NOTE: If the vehicle under test does not support the DPF Regeneration Procedure, an "information" screen displays the procedures for "passive" DPF regeneration. Choose **Back** to return to the DPF Reset menu.

4. Choose **Next** to continue.
 - An "informational" screen displays the procedures for "passive" or "active" DPF regeneration, as applicable. Choose **Back** to return to the DPF Reset Menu.
5. Tap **DPF OBD Service**.
 - A "One moment" message displays, followed by the Diesel Particulate Filter Reset menu. Select the desired option.

- An “instructional” screen displays. Prepare the vehicle for the procedure as directed.
6. Choose **Next** to continue.
- A series of “status” screens display while the routine is in process.
 - A “confirmation” screen displays when the routine is completed.

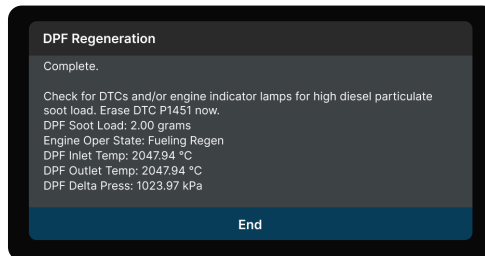

 **NOTE:** If the routine does not complete successfully, an “advisory” message displays. Choose **Exit** to return to the DPF Reset menu.

7. Tap **End** to return to the DPF Reset menu, then tap the ← icon at the top of the page to return to the Workshop Tools screen.

RESET ELECTRIC TRACTION SYSTEM

Use this feature to calibrate the Yaw Rate Sensor after replacement of the ABS ECU and Yaw Rate / G sensor.

 **NOTE:** The function procedures vary between vehicle makes and models.

1. Tap **Reset Electric Traction System** on the Workshop Tools screen.

 **NOTE:** If **Reset Electric Traction System** is not supported by the vehicle under test, an “advisory” message displays. Tap **Exit** to return to the Workshop Tools screen.

- A “One moment please...” progress dialog displays. Tap **Cancel** to cancel the operation.
2. Once ready, the Reset Electric Traction System menu displays.

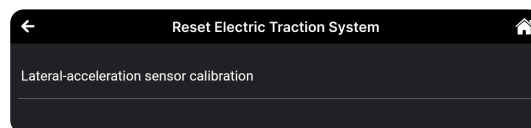

3. Select the desired option, then perform the procedures as directed. Tap **Yes** or **Continue**, as appropriate, to scroll to the next screen, or, tap **No**, **Exit** or **Cancel** to terminate the procedure.

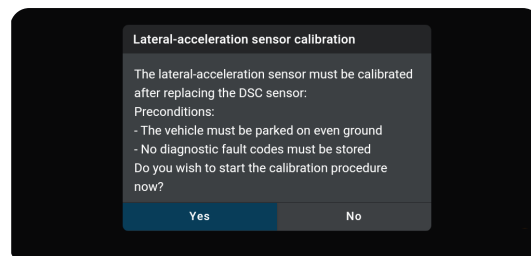

4. A “results” screen displays when the reset procedure has been completed. Tap **Exit** to terminate the procedure.

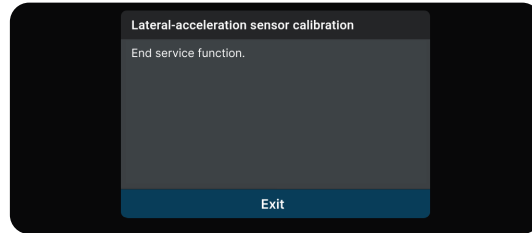

5. Tap the ← icon at the top of the page to return to the Workshop Tools screen.

IMMOBILIZER RESET

This function allows you to reset the ignition immobilizer after the ignition switch key, ignition switch, combined instrument panel, ECU, BCM, or remote-control battery is replaced.



NOTE: The function procedures vary between vehicle makes and models.

1. Tap **Immobilizer Reset** on the Workshop Tools screen.



NOTE: If Immobilizer Reset is not supported by the vehicle under test, an “advisory” message displays. Tap **Exit** to return to the Workshop Tools screen.

- A “One moment please...” progress dialog displays. Tap **Cancel** to cancel the operation.

2. Once ready, the Immobilizer Reset menu displays.

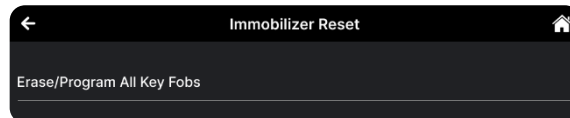

3. Select the desired option, then perform the procedures as directed. Tap **Next** or **Learn**, as appropriate, to scroll to the next screen, or, tap **Exit** or **Cancel** to terminate the procedure.

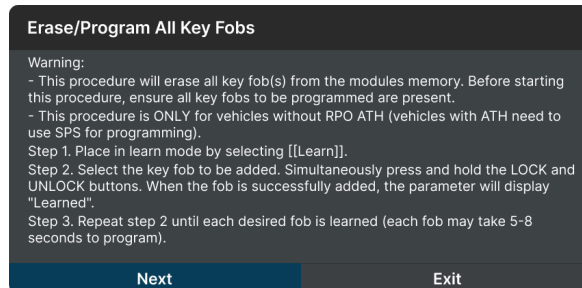

4. A “results” screen displays when the reset procedure has been completed. Tap **Exit** to terminate the procedure.

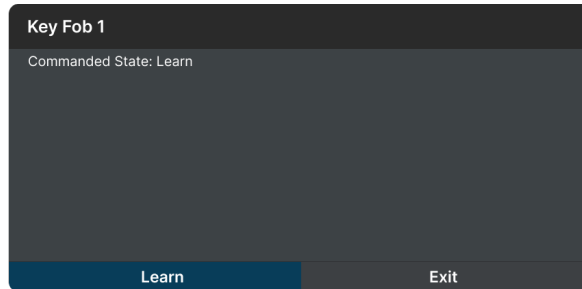

5. Tap the ← icon at the top of the page to return to the Workshop Tools screen.

READ/WRITE ODOMETER SETTINGS

Use this function to copy, write, or rewrite the actual (legally correct) vehicle distance travelled (in miles or kilometers) to the vehicle's odometer chip.

Use this function to perform different settings to be modified in the combined instrument panel.



NOTE: The function procedures vary between vehicle makes and models.

1. Tap **Read/Write Odometer Settings** on the Workshop Tools screen.



NOTE: If Read/Write Odometer Settings is not supported by the vehicle under test, an "advisory" message displays. Tap **Exit** to return to the Workshop Tools screen.

- A "One moment please..." progress dialog displays. Tap **Cancel** to cancel the operation.

2. One or more sub-menus will display. Select the desired options, then proceed to **step 3**.

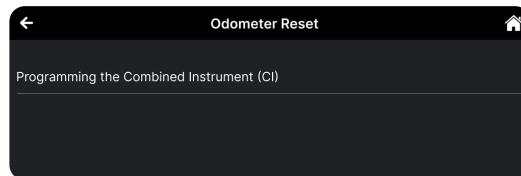

3. Select the desired option, then perform the procedures as directed. Tap **Next**, as appropriate, to scroll to the next screen, or, tap **Exit** or **Cancel** to terminate the procedure.

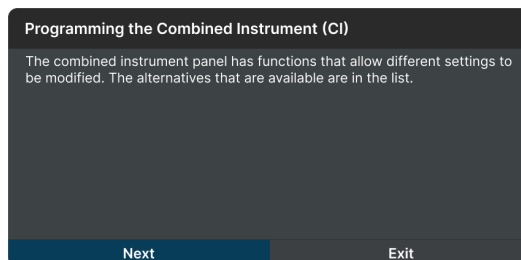

4. A "results" screen displays when the reset procedure has been completed. Tap **Back** to terminate the procedure.

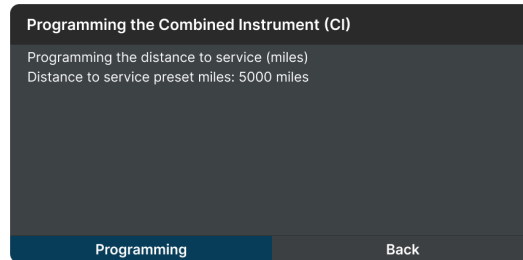

- Tap the ← icon at the top of the page to return to the Workshop Tools screen.

LANGUAGE CHANGE RESET

Allows changing the displayed language in the cabin compartment or updates the language displayed in the cluster.



NOTE: The function procedures vary between vehicle makes and models.

- Tap **Language Change Reset** on the Workshop Tools screen.



NOTE: If Language Change Reset is not supported by the vehicle under test, an “advisory” message displays. Tap **Exit** to return to the Workshop Tools screen.

- A “One moment please...” progress dialog displays. Tap **Cancel** to cancel the operation.
- Once ready, the Language Change Reset menu displays.

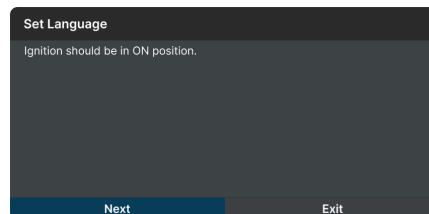

- Select the desired language. Tap **Exit** to terminate the procedure.

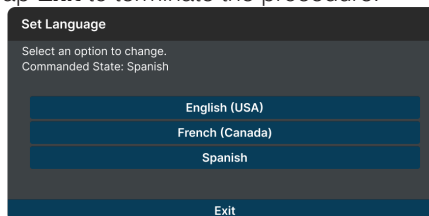

- Tap the ← icon at the top of the page to return to the Workshop Tools screen.

NOX SENSOR RESET

The NOx sensor detects the content of nitrogen oxides (NOx) in the engine’s exhaust. In cases where the NOx catalytic converter is replaced or an NOx fault is re-initialized, it is necessary to reset the catalytic converter learned values stored in the vehicle’s Engine Control Unit (ECU). Use the NOx Sensor Reset function to reset these values after replacing the NOx catalytic converter or re-initializing the fault.



NOTE: The function procedures vary between vehicle makes and models.

1. Tap **NOx Sensor Reset** on the Workshop Tools screen.



NOTE: If NOx Sensor Reset is not supported by the vehicle under test, an “advisory” message displays. Tap **Exit** to return to the Workshop Tools screen.

- A “One moment please...” progress dialog displays. Tap **Cancel** to cancel the operation.

2. Once ready, the NOx Sensor Reset menu displays.

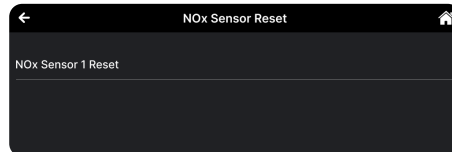

3. Select the desired option. Tap **Reset** to perform the selected procedure, or, tap **Exit** to return to the NOx Sensor Reset menu.

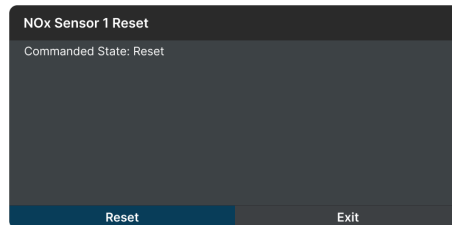

4. Tap the ← icon at the top of the page to return to the Workshop Tools screen.

CYLINDER RESET

Use this function to analyze the behavior of each engine cylinder. If a cylinder has a deviation of more than 6 RPM compared with the engine speed, there is a high possibility that the cylinder has a compression problem.



NOTE: The function procedures vary between vehicle makes and models.

1. Select **Cylinder Reset** on the Workshop Tools screen.



NOTE: If Cylinder Reset is not supported by the vehicle under test, an “advisory” message displays. Tap **Exit** to return to the Workshop Tools screen.

- A “One moment please...” progress dialog displays. Tap **Cancel** to cancel the operation.

2. Once you select a module to perform the Cylinder Reset function, the Cylinder Reset menu displays.
3. Select the desired option, then perform the procedures as directed. Tap **Next** to scroll to the next screen, or, tap **Exit** or **Cancel** to terminate the procedure.

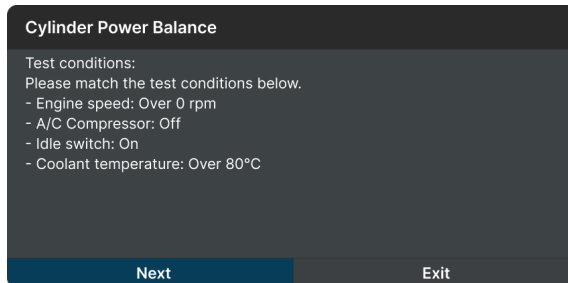

4. A "results" screen displays when the reset procedure has been completed. Tap **Exit** to terminate the procedure.

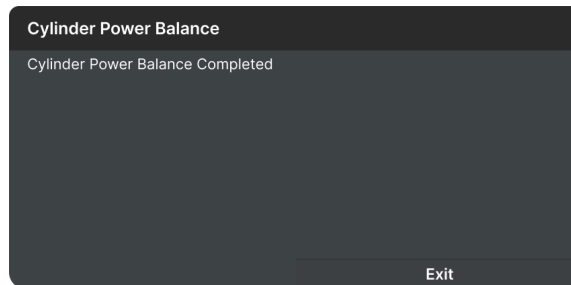

5. Tap the ← icon at the top of the page to return to the Workshop Tools screen.

ADBLUE RESET

After the diesel exhaust treatment fluid is replaced or refilled, a reset operation is required. The Adblue reset function allows you to reset the system to the specified fill level.



NOTE: *The function procedures vary between vehicle makes and models.*

1. Tap **Adblue Reset** on the Workshop Tools screen.



NOTE: *If Adblue Reset is not supported by the vehicle under test, an "advisory" message displays. Tap **Exit** to return to the Workshop Tools screen.*

- A "One moment please..." progress dialog displays. Tap **Cancel** to cancel the operation.
2. Once ready, the Adblue Reset menu displays. Select **Reset** to perform the procedures as directed.
3. Tap **Next**, as appropriate, to scroll to the next screen, or, tap **Exit** or **Cancel** to terminate the procedure.

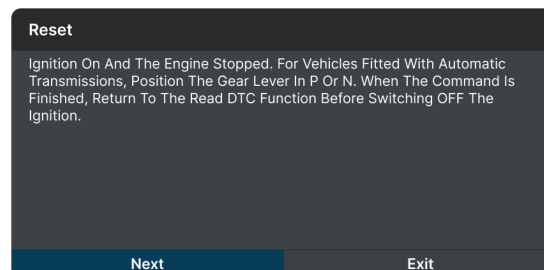

4. A "results" screen displays when the reset procedure has been completed. Tap **Exit** to terminate the procedure.

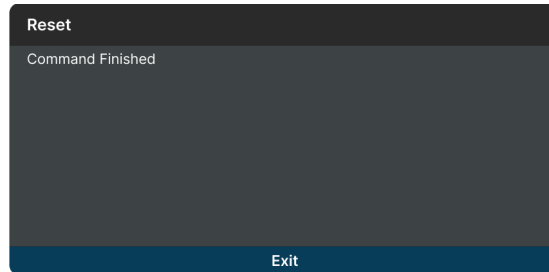

5. Tap the ← icon at the top of the page to return to the Workshop Tools screen.

HV BATTERY RESET

Resets or recalibrates the HV battery system after maintenance, replacement, or system faults in hybrid/electric vehicles.



NOTE: The function procedures vary between vehicle makes and models.

1. Tap **HV Battery Reset** on the Workshop Tools screen.



NOTE: If HV Battery Reset is not supported by the vehicle under test, an “advisory” message displays. Tap **Exit** to return to the Workshop Tools screen.

2. A “One moment please...” message displays, followed by one or more “informational/instructional” or “selection” screens.

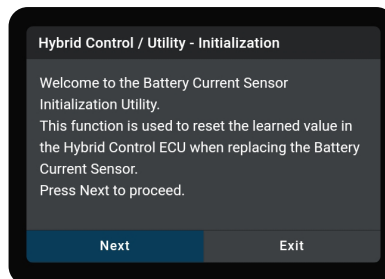

- Tap **Next**, as appropriate, to proceed to the next screen, or, tap **Exit** or **Cancel** to terminate the procedure.
3. Prepare the vehicle as directed. Tap **Next** or **Continue**, as appropriate, to scroll to the next screen, or, tap **Exit** or **Cancel** to terminate the procedure.

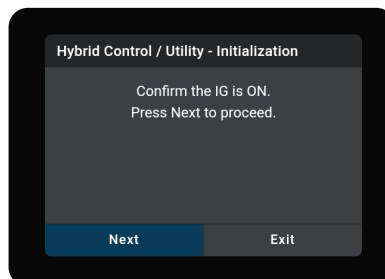

4. A “results” screen displays when the reset procedure has been completed. Tap **Exit** to terminate the procedure.

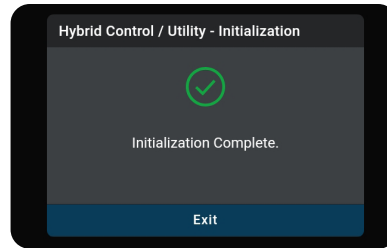

5. Tap **Yes** to exit the initialization.
6. Tap the ← icon at the top of the page to return to the Workshop Tools screen.

RAIN/LIGHT SENSOR RESET

Resets the rain and light sensors to ensure proper function after maintenance, sensor faults, or battery replacement.



NOTE: The function procedures vary between vehicle makes and models.

1. Tap **Rain/Light Sensor Reset** on the Workshop Tools screen.



NOTE: If Rain/Light Sensor Reset is not supported by the vehicle under test, an “advisory” message displays. Tap **Exit** to return to the Workshop Tools screen.

2. A “One moment please...” message displays, followed by one or more “informational/instructional” or “selection” screens.
 - Tap **Next** or **Continue**, as appropriate, to proceed to the next screen, or, tap **Exit** or **Cancel** to terminate the procedure.

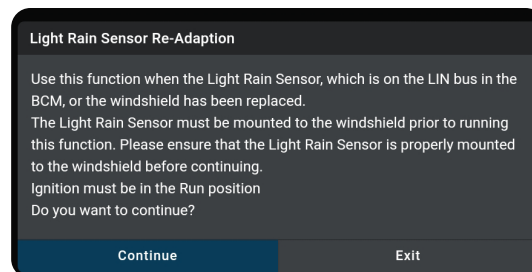

3. Perform the test conditions as directed. Tap **Next** or **Continue**, as appropriate, to scroll to the next screen, or, tap **Exit** or **Cancel** to terminate the procedure.

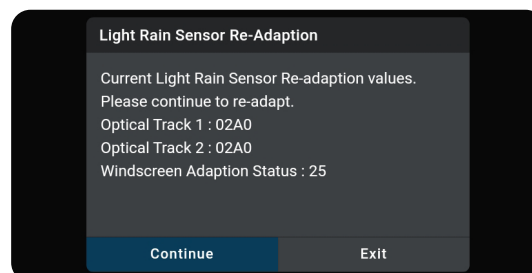

4. A “results” screen displays when the reset procedure has been completed. Tap **Finish** to terminate the procedure.

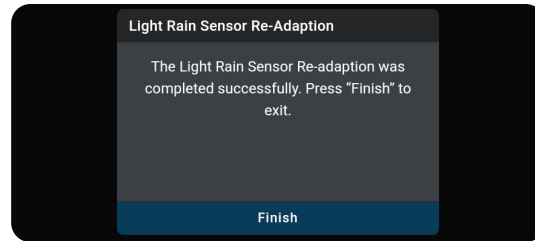

5. Tap the ← icon at the top of the page to return to the Workshop Tools screen.

EGR RESET

Performs a reset of the Exhaust Gas Recirculation (EGR) system to clear learned values or errors. This is typically required after maintenance or when resolving EGR-related performance issues.



NOTE: The function procedures vary between vehicle makes and models.

1. Select **EGR Reset** on the Workshop Tools screen.

- A “One moment please...” message displays.



NOTE: If EGR Reset is not supported by the vehicle under test, an “advisory” message displays. Tap **Exit** to return to the Workshop Tools screen.

- One or more sub-menus will display. Select the desired options, then proceed to **step 2**.

2. Instruction screens may display. Follow the directions and select **Increase** or **Decrease**, as appropriate.

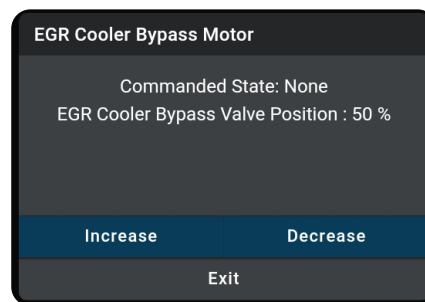

3. For some vehicles, “status” screens display as each phase of the procedure is successfully completed.

- A “results” screen displays when the procedure has been completed.

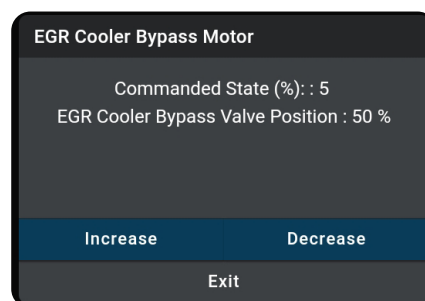

4. Tap **Exit** to close the results message, or tap **Increase** or **Decrease** to continue.

5. Tap the ← icon at the top of the page to return to the Workshop Tools screen.

ELECTRONIC WATER PUMP START RESET

This function clears errors or resets settings in the water pump's control system, typically after maintenance.



NOTE: The function procedures vary between vehicle makes and models.

1. Select **Electronic Water Pump Start Reset** on the Workshop Tools screen.
 - A "One moment please..." message displays.



NOTE: If Electronic Water Pump Start Reset is not supported by the vehicle under test, an "advisory" message displays. Tap **Exit** to return to the Workshop Tools screen.

- One or more sub-menus will display. Select the desired options, then proceed to **step 2**.
2. Follow on-screen instructions. Tap **Next** to proceed.

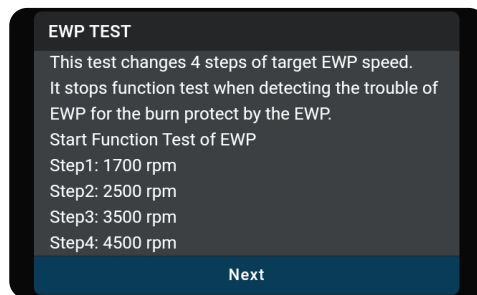

3. Operate the vehicle according to the conditions shown.

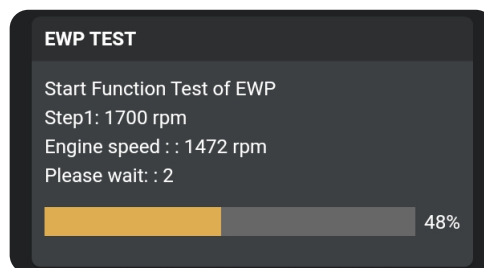

4. A "results" screen displays when the reset procedure has been completed. Tap **Next** to terminate the procedure.

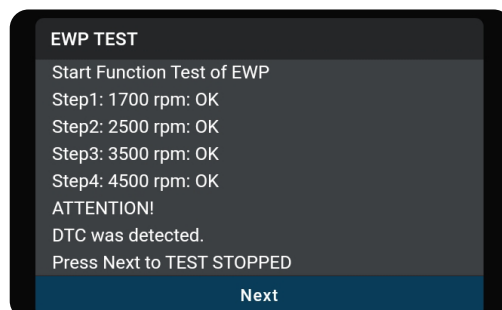

5. Tap the ← icon at the top of the page to return to the Workshop Tools screen.

TIRE SIZE RESET

Whenever different size tires are installed on a vehicle the speedometer will no longer read the correct speed. With larger tires, the speedometer may indicate a slower speed than in actuality; and with smaller tires, the speedometer will indicate a faster speed. Use this function to reset the tires after installing different size tires on a vehicle.



NOTE: The function procedures vary between vehicle makes and models.

1. Select **Tire Size Reset** on the Workshop Tools screen.
 - A “One moment please...” message may display.
 - One or more sub-menus will display. Select the desired options, then proceed to **step 2**.



NOTE: If Tire Size Reset is not supported for the vehicle under test, an “advisory” message displays. Tap **Exit**, as necessary, to return to the Workshop Tools screen.

2. One or more “informational/instructional” screens display.
 - Perform reset procedures as directed. Choose **Next** or **Continue**, as appropriate, to scroll to the next screen.

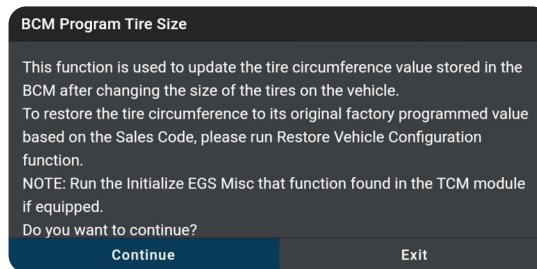

3. For some vehicles, “status” screens display as each phase of the reset procedure is successfully completed. Choose **Next** or **Continue**, as appropriate, to scroll to the next screen.
 - A “results” screen displays when the procedure has been completed.

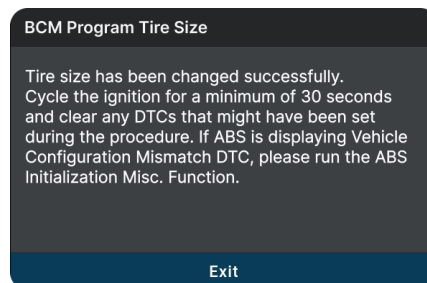

4. Tap **Exit** to close the results message.
5. Tap the ← icon at the top of the page to return to the Workshop Tools screen.

STOP/START RESET

The automatic stop/start system shuts down and restarts the vehicle's engine to minimize idle time, reducing fuel consumption and vehicle emissions.



NOTE: The function procedures vary between vehicle makes and models.

1. Select **Stop/Start Reset** on the Workshop Tools screen.
 - A "One moment please..." message may display.



NOTE: If Stop/Start Reset is not supported for the vehicle under test, an "advisory" message displays. Tap **Exit**, as necessary, to return to the Workshop Tools screen.

2. One or more "informational/instructional" screens display. Choose **Next** or **Continue**, as appropriate, to scroll to the next screen.
3. Perform the test conditions as directed. Tap **Next** or **Continue**, as appropriate, to scroll to the next screen, or, tap **Back** or **Cancel** to terminate the procedure.

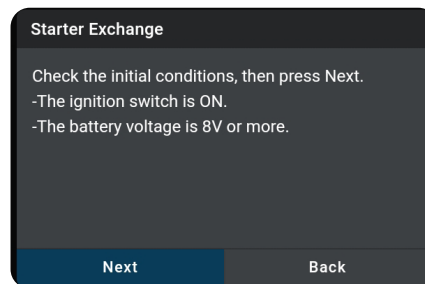

4. Operate the vehicle according to the conditions shown.

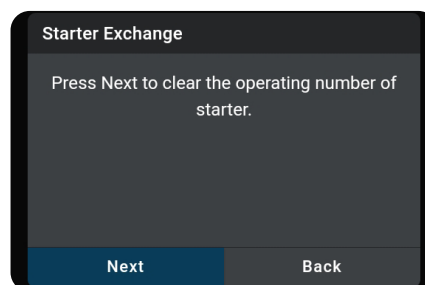

5. A "results" screen displays when the reset procedure has been completed. Tap **Exit** to terminate the procedure.

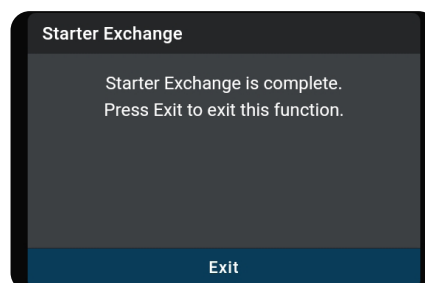

6. Tap the ← icon at the top of the page to return to the Workshop Tools screen.

RELEARNS

TPMS RELEARN

Use this function to initialize/relearn the Tire Pressure Monitoring System, or TPMS, and turn off a TPMS light/message on the dashboard. You can also use this function to write the ID of a new sensor to the control module whenever a TPMS sensor is replaced.



NOTE: The function procedures vary between vehicle makes and models.

1. Tap **TPMS Relearn** on the Workshop Tools screen.



NOTE: If TPMS Relearn is not supported by the vehicle under test, an “advisory” message displays. Tap **Exit** to return to the Workshop Tools screen.

- A “One moment please...” progress dialog displays. Tap **Cancel** to cancel the operation.
2. Once ready, the TPMS Relearn menu displays.

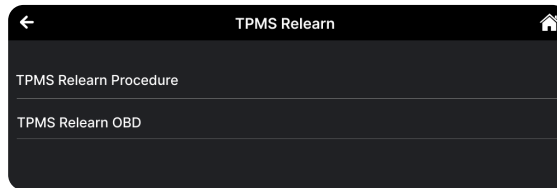

3. Tap **TPMS Relearn Procedure**.

- The TPMS Relearn Procedure screen displays. Tap **Exit** to return to the TPMS Relearn menu.

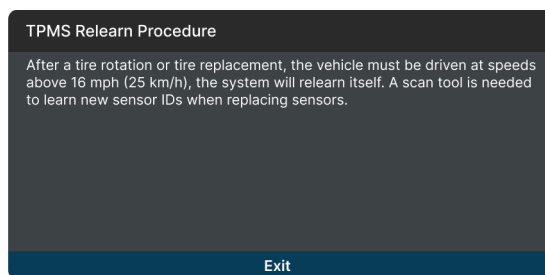

4. Tap **TPMS Relearn OBD**.

- An “instructional” screen displays. Prepare the vehicle for relearn as directed.

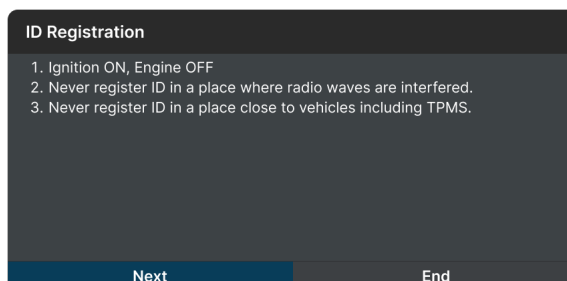

- Select the desired option, then perform the relearn procedures as directed. Tap **Next** or **Continue**, as appropriate, to scroll to the next screen, or, tap **End** or **Cancel** to terminate the procedure.
5. A “results” screen displays when the relearn procedure has been completed. Tap **End** to terminate the procedure.

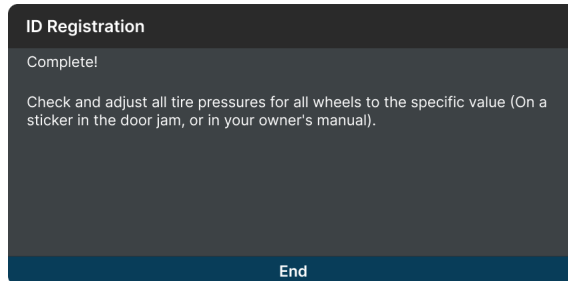

6. Tap the ← icon at the top of the page to return to the Workshop Tools screen.

THROTTLE BODY RELEARN/TEC LEARN

Modern vehicles use electronic throttle body sensors. Carbon buildup can change the throttle’s home position, and the PCM adapts over time. After cleaning, replacing, or disconnecting the throttle body—or after battery disconnection—the PCM may lose or keep outdated settings. This function helps the PCM relearn the correct throttle position to keep idle within the specified range.



NOTE: *The function procedures vary between vehicle makes and models.*

1. Tap **Throttle Body Relearn/TEC Learn** on the Workshop Tools screen.



NOTE: *If Throttle Body Relearn/TEC Learn is not supported by the vehicle under test, an “advisory” message displays. Tap **Exit** to return to the Workshop Tools screen.*

- A “One moment please...” progress dialog displays. Tap **Cancel** to cancel the operation.
2. Once ready, the Throttle Body Relearn/TEC Learn menu displays.
 3. Tap **Throttle Body Relearn Procedure**.
 - The Throttle Body Relearn Procedure screen displays. Tap **Exit** to return to the Throttle Body Relearn/TEC Learn menu.

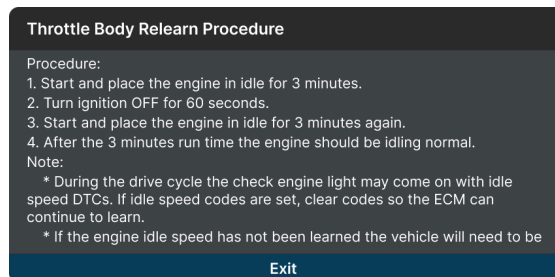

4. Tap **Idle Learn Reset**.
 - An “instructional” screen displays. Tap **Reset** to perform the procedures as directed, or, tap **Exit** or **Cancel** to terminate the procedure.

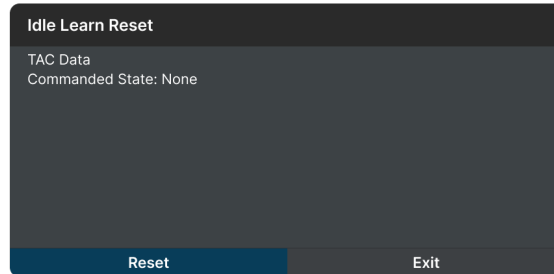

5. A “results” screen displays when the relearn procedure has been completed. Tap **Exit** to terminate the procedure.

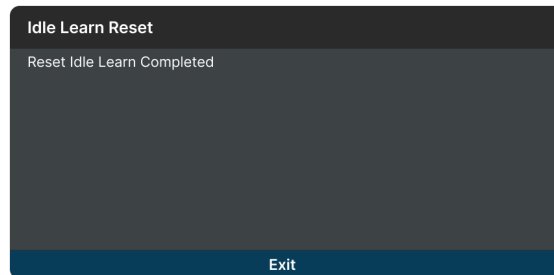

6. Tap the ← icon at the top of the page to return to the Workshop Tools screen.

AC SYSTEM RELEARN

Use this function to re-learn the A/C equipment status after a vehicle's PCM has been replaced.



NOTE: The function procedures vary between vehicle makes and models.

1. Select **AC System Relearn** on the Workshop Tools screen.

- A “One moment please...” message displays.



NOTE: If AC System Relearn is not supported for the vehicle under test, an “advisory” message displays. Tap **Exit**, as necessary, to return to the Workshop Tools screen.

2. One or more “informational/instructional” screens display.
 - One or more sub-menus will display. Select the desired options, then proceed to **step 2**.
2. One or more “informational/instructional” screens display.
 - Choose **Start**, as appropriate, to perform the function.

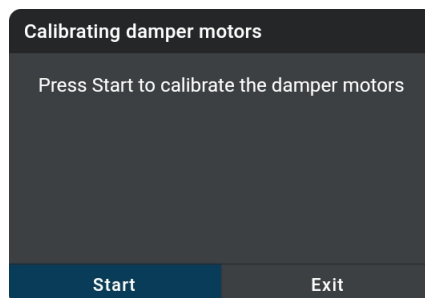

3. The screen refreshes to show results.

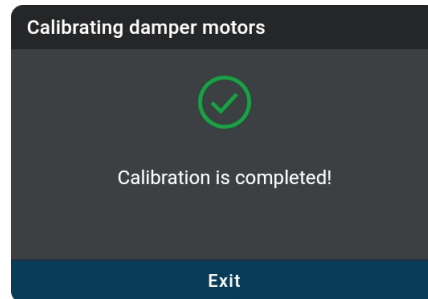

4. Tap **Exit** to close the results message.
5. Tap the ← icon at the top of the page to return to the Workshop Tools screen.

CLUTCH RELEARN

Use this function to re-learn the clutch pedal up-stop and down-stop values after an ECU or clutch pedal replacement.



NOTE: The function procedures vary between vehicle makes and models.

1. Tap **Clutch Relearn** on the Workshop Tools screen.



NOTE: If Clutch Relearn is not supported by the vehicle under test, an “advisory” message displays. Tap **Exit** to return to the Workshop Tools screen.

- A “One moment please...” progress dialog displays. Tap **Cancel** to cancel the operation.
2. Once ready, the Clutch Relearn menu displays.
 3. Select the desired option, then perform the test procedures as directed. Tap **Next** or **Continue**, as appropriate, to scroll to the next screen, or, tap **Exit** or **Cancel** to terminate the procedure.

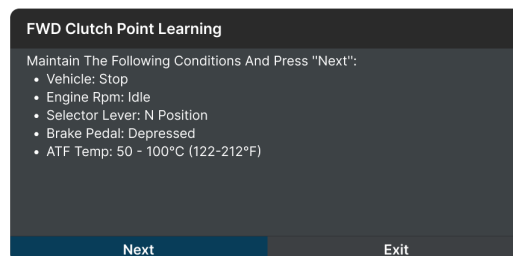

4. A “results” screen displays when the relearn procedure has been completed. Tap **Exit** to terminate the procedure.

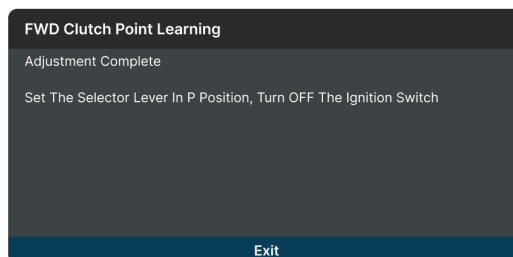

5. Tap the ← icon at the top of the page to return to the Workshop Tools screen.

ROUTINES

ABS BLEEDING

When brake fluid is added, replaced, or drained, or when ABS-related parts (computer, pump, master cylinder, brake cylinder, or brake line) are replaced, use the ABS Bleeding function to remove any air from the system.



NOTE: The function procedures vary between vehicle makes and models.

1. Tap **ABS Bleeding** on the Workshop Tools screen.
 - One or more sub-menus will display. Select the desired options, then proceed to **step 2**.



NOTE: If ABS Bleeding is not supported for the vehicle under test, an “advisory” message displays. Tap **Retry**, as necessary, to return to the Workshop Tools menu.

2. One or more “informational/instructional” screens display.
 - Perform procedures as directed. Tap **Next** to scroll to the next step.

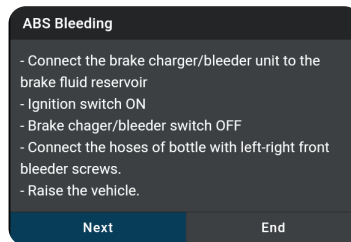

3. For some vehicles, “status” screens display as each phase of the procedure is successfully completed. Tap **Next** to scroll to the next step.
 - A “results” message displays when the procedure has completed.

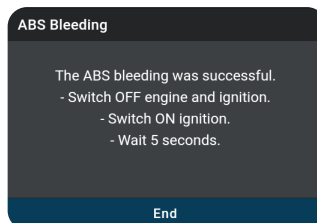

4. Tap **End** to close the results message.
5. Tap the ← icon at the top of the page to return to the Workshop Tools screen.

BATTERY/ALTERNATOR TEST

The tablet can check the vehicle’s battery and alternator systems to ensure operation is within acceptable limits. You can test just the battery (**Battery Test**) or check both the battery and alternator (**Alternator Test**).

Battery Test

1. Tap **Battery/Alternator Test** on the Workshop Tools screen.

- The Battery/Alternator Test menu displays.

2. Tap **Battery Test**.

- An “instructional” message displays, showing the procedures to prepare the vehicle for the battery check.

3. Prepare the vehicle for the battery check:

- Turn the engine off.
- Place the transmission in PARK or NEUTRAL, and set the parking brake.
- Make a visual check of the battery’s condition. If the battery terminals are corroded or other damage is present, clean or replace the battery as appropriate.
- For “unsealed” batteries, make sure the water level in each cell is above the battery plates.
- Turn the ignition on. **DO NOT** start the engine.

4. Tap **Continue** to proceed.



NOTE: If the engine is running, an “advisory” message displays. Turn the engine off, then turn the ignition on. **DO NOT** start the engine. Tap **Continue** to proceed.

- An “instructional” message displays.

5. Turn the vehicle’s headlights on, then tap **Continue** to proceed.

- A “countdown” message displays while the battery check is in process.

6. Turn the vehicle’s headlights off, then tap **Continue** to proceed.

- An “instructional” message displays.
- If battery voltage is *less than* 12.1 volts, an “advisory” message displays. Tap **Home** to return to the Home screen. Turn the ignition off and disconnect the tablet from the vehicle. Fully charge the battery, then repeat the battery check.
- If battery voltage is *between* 11.8 and 12.1 volts, a “Battery voltage is low, this may affect the accuracy of the test result.” message displays.
- If battery voltage is *greater than* 12.1 volts, an “instructional” message displays.

7. Start the vehicle’s engine. Allow the engine to run for several seconds, then turn the engine off. Repeat for a total of three “start/stop” cycles.



NOTE: If the tablet did not detect “cranking status” for the vehicle’s engine, an “advisory” message displays. Tap **Retest** to repeat the battery check, or choose **Exit** to return to the Home screen.

8. When the battery check is complete, a results screen displays the battery status.

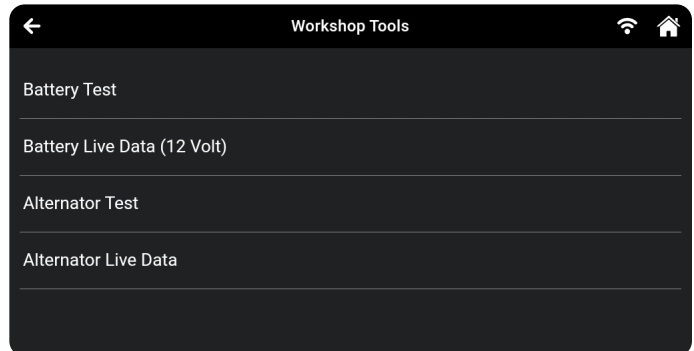

9. Tap **End** to return to the Battery/Alternator Test menu.
10. Tap the  icon at the top of the page to return to the Workshop Tools screen.

View Battery Live Data (12 Volt)

1. Tap **Battery/Alternator Test**.
 - The Battery/Alternator Test menu displays.
2. Tap **Battery Live Data (12 Volts)**.
 - The Battery Live Data (12 Volts) screen displays.
 - When you are finished viewing the Battery Live Data (12 Volts), tap the **Back** button to return to the Battery/ Alternator Test menu.

Alternator Test

1. Tap **Battery/Alternator Test** on the Workshop Tools screen.
 - The Battery/Alternator Test menu displays.
2. Tap **Alternator Test**.
3. An “instructional” message displays. Start and warm the engine to normal operating temperature. Turn on the headlights. Tap **Continue** to proceed.
 - An “instructional” message displays.
 - Follow the instructions.
4. When the alternator check is complete, a results screen shows charging system voltage and indicates whether the charging system is within acceptable limits.
5. Tap **Exit** to return to the Battery/Alternator Test menu.
6. Tap the  icon at the top of the page to return to the Workshop Tools screen.

View Alternator Live Data

1. Tap **Battery/Alternator Test**.
 - The Battery/Alternator Test menu displays.
2. Tap **Alternator Live Data**.
 - The Alternator Live Data screen displays.
3. When you are finished viewing the Alternator Live Data, choose **Back** to return to the Battery/Alternator Test menu.

EV/HEV/PHEV BATTERY HEALTH

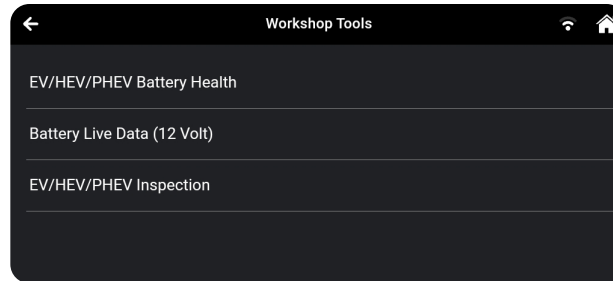

The tablet provides the ability to check the battery health for a variety of electric powered vehicles, including: Electric Vehicle (EV), Hybrid-Electric Vehicle (HEV), and Plug-In Hybrid Electric Vehicle (PHEV).

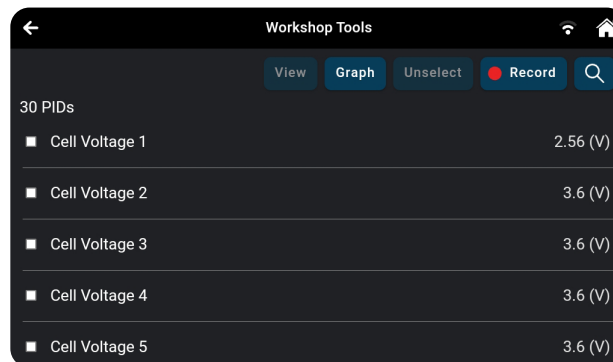

EV/HEV/PHEV Battery Health

1. Tap **EV/HEV/PHEV Battery Health** on the Workshop Tools screen.
 - The EV/HEV/PHEV Battery Health menu displays.
2. Tap **EV/HEV/PHEV Battery Health**.
 - The Live Data dialog page displays with corresponding PIDs.



3. Select the **PID(s)** you wish to explore.
 - A “checkmark” indicates the associated PID *is selected* for viewing.
 - An “empty checkbox” indicates the PID is *not selected* for viewing.
 - Tapping a checkbox repeatedly will toggle it on and off.
 - Tap the **Unselect** button to unselect *all* PIDs.
4. Tap the “**search**”  icon to quickly search for the PID(s) you wish to view or graph.
 - Use the keyboard to type in the name of the PID(s) and select as desired.
 - Tap the “**hide search**”  icon to exit the search function and return to the PID list.
5. Tap the **View** button to view data for the selected PIDs in tabular mode.
 - Each entry in the table shows the name of the PID, and a numerical representation of the current value for the PID.
 - Tap **PID List** to return to the full PID results list. (*Step 2 above*).
6. Tap the **Graph** button to view the selected PIDs in graph mode.

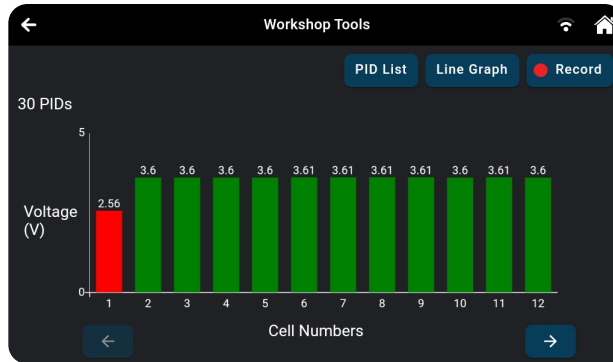

7. The **Line Graph** button displays battery voltage PIDs in line graph format.

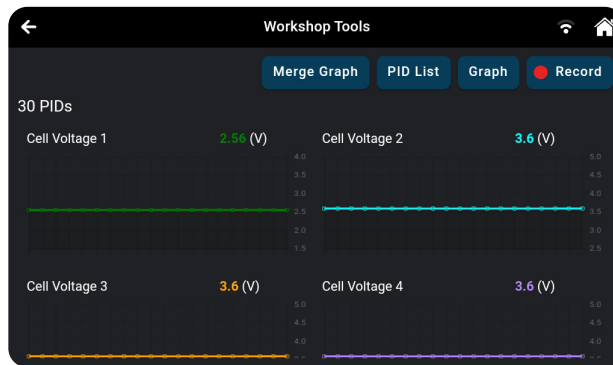

- Tap the **PID List** button to return to the PID selection screen.

8. The **Record** button records selected PIDs.

9. Tap the **←** icon at the top of the page to return to the Workshop Tools screen.

EV/HEV/PHEV Inspection

1. Tap **EV/HEV/PHEV Battery Health** on the Workshop Tools screen.

- The EV/HEV/PHEV Battery Health menu displays.

2. Tap **EV/HEV/PHEV Inspection**.

- The EV/HEV/PHEV Inspection screen displays with corresponding PIDs.

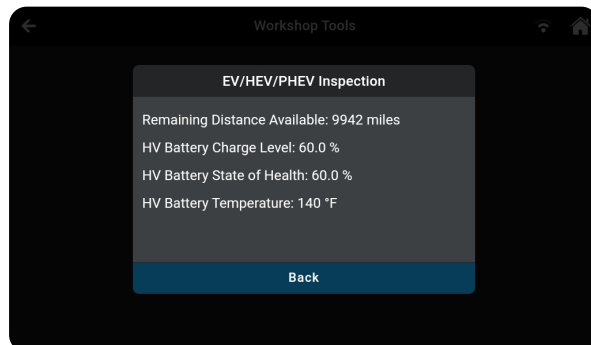

TRANSMISSION FLUID TEMPERATURE

Depending on the vehicle under test, the tablet allows you to view temperature readings from the Transmission Fluid Temperature Sensor (TFT) to help identify transmission overheating issues.

1. Tap **Transmission Fluid Temperature** on the Workshop Tools screen.
 - A “One moment please...” progress dialog displays. Tap **Cancel** to cancel the operation.
2. The Transmission Temperature Live Data PID list displays.

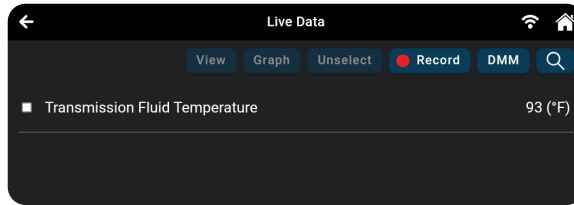

3. Select the PID(s) you wish to view and tap **View**, **Graph**, **Record** or **DMM**. [See page 27]
 - Tap **Unselect** to unselect all PID parameters.
4. Tap the ← icon at the top of the page to return to the Workshop Tools screen.

TRANSMISSION FLUID LEVEL CHECK

This function allows you to check the vehicle’s transmission fluid level.



NOTE: The function procedures vary between vehicle makes and models.

1. Select **Transmission Fluid Level Check** on the Workshop Tools screen.
 - A “One moment please...” message displays.



NOTE: If Transmission Fluid Level Check is not supported for the vehicle under test, an “advisory” message displays. Tap **Exit**, as necessary, to return to the Workshop Tools screen.

2. One or more “informational/instructional” screens display.
 - Perform procedures as directed. Choose **Next** or **Continue**, as appropriate, to scroll to the next screen.

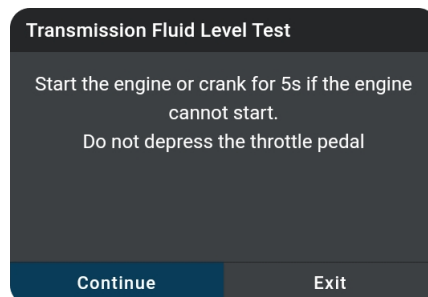

3. For some vehicles, “status” screens display as each phase of the procedure is successfully completed. Choose **Next** or **Continue**, as appropriate, to scroll to the next screen.
 - A “results” screen displays when the procedure has completed.

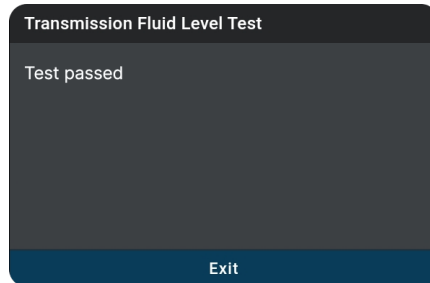

4. Tap **Exit** to close the results message.
5. Tap the ← icon at the top of the page to return to the Workshop Tools screen.

INJECTOR CODING

This function sets the injector adjustment values after installing new diesel fuel injectors so it can properly communicate with the vehicle’s digital Electronic Control Unit (ECU).



NOTE: *The function procedures vary between vehicle makes and models.*

1. Select **Injector Coding** on the Workshop Tools screen.
 - A “One moment please...” message displays.



NOTE: *If Injector Coding is not supported for the vehicle under test, an “advisory” message displays. Tap **Exit**, as necessary, to return to the Workshop Tools screen.*

- One or more sub-menus will display. Select the desired options, then proceed to **step 2**.
2. One or more “informational/instructional” screens display.

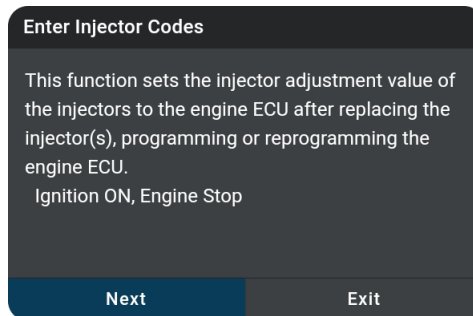

- Perform coding procedures as directed. Choose **Next** or **Continue**, as appropriate, to scroll to the next screen.
3. For some vehicles, “status” screens display as each phase of the coding procedure is successfully completed. Choose **Next** or **Continue**, as appropriate, to scroll to the next screen.
 - A “results” screen displays when the procedure has been completed.

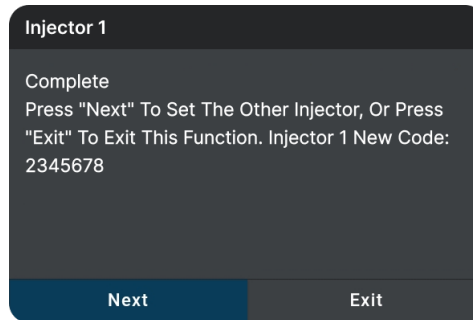

4. Tap **Exit** to close the results message.
5. Tap the ← icon at the top of the page to return to the Workshop Tools screen.

WINDOW DOOR ROOF

Use the Window Door Roof function to reset the zero (stop) point for window, door, and sunroof sensors after replacement or servicing.

Additionally, this function supports configuration of various settings such as locking of the sunroof, automatic closing during rainfall, memory function for sliding/tilting sunroof, and adjustment of the outside temperature threshold.



NOTE: *The function procedures vary between vehicle makes and models.*

1. Select **Window Door Roof** on the Workshop Tools screen.

- A “One moment please...” message displays.



NOTE: *If Window Door Roof is not supported for the vehicle under test, an “advisory” message displays. Tap **Exit**, as necessary, to return to the Workshop Tools screen.*

- One or more sub-menus will display. Select the desired options, then proceed to **step 2**.
2. One or more “informational/instructional” screens display.
 - Perform procedures as directed. Choose **Next** or **Continue**, as appropriate, to scroll to the next screen.

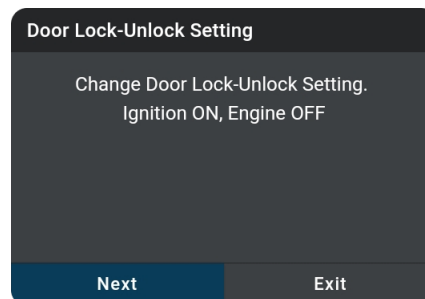

3. For some vehicles, “status” screens display as each phase of the procedure is successfully completed. Choose **Next** or **Continue**, as appropriate, to scroll to the next screen.
 - A “results” screen displays when the procedure has been completed.

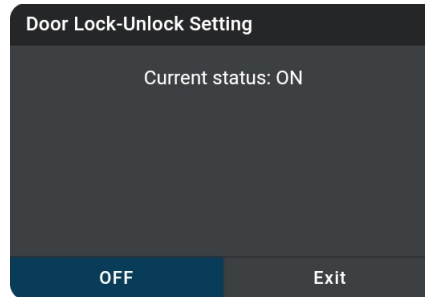

4. Tap **Exit** to close the results message.
5. Tap the ← icon at the top of the page to return to the Workshop Tools screen.

KEY CODING PROCEDURE

Use this function to add (program) a new key fob and remotely disable a lost key – preventing the vehicle from being stolen in the future.



NOTE: The function procedures vary between vehicle makes and models.

1. Select **Key Coding Procedure** on the Workshop Tools screen.
 - A “One moment please...” message displays.



NOTE: If the Key Coding Procedure is not supported for the vehicle under test, an “advisory” message displays. Tap **Exit**, as necessary, to return to the Workshop Tools screen.

- The Key Coding Procedure menu displays.
2. Tap the procedure you wish to view.
 - The screen shows the procedure for the option you selected.

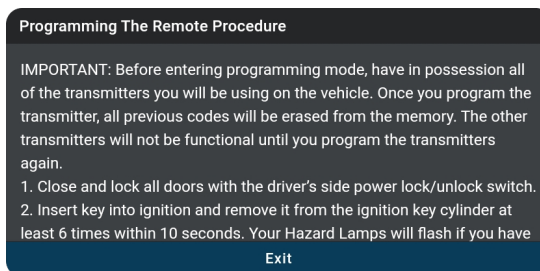

3. Tap **Exit** to close the procedure screen.
4. Tap the ← icon at the top of the page to return to the Workshop Tools screen.

A/F SETTING

Allows you to set or re-learn Air/Fuel ratio mix parameters.



NOTE: The function procedures vary between vehicle makes and models.

1. Select **A/F Setting** on the Workshop Tools screen.
 - A “One moment please...” message displays.



NOTE: If A/F Setting is not supported for the vehicle under test, an “advisory” message displays. Tap **Exit**, as necessary, to return to the Workshop Tools screen.

- One or more sub-menus will display. Select the desired options, then proceed to **step 2**.
2. One or more “informational/instructional” screens display.

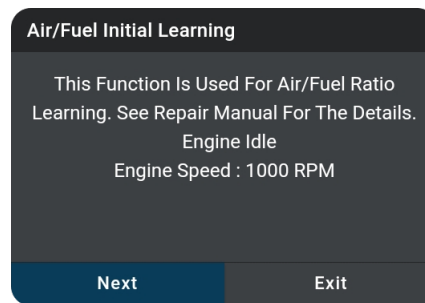

- Perform procedures as directed. Choose **Next** or **Continue**, as appropriate, to scroll to the next screen.
3. For some vehicles, “status” screens display as each phase of the procedure is successfully completed. Choose **Next** or **Continue**, as appropriate, to scroll to the next screen.
 - A “results” screen displays when the procedure has been completed.

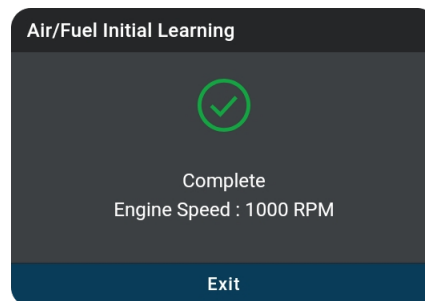

4. Tap **Exit** to close the results message.
5. Tap the ← icon at the top of the page to return to the Workshop Tools screen.

TRANSPORT MODE

In order to reduce power consumption while the vehicle is in transit, certain functions may be disabled, including limiting the vehicle speed, not waking up the door opening network, disabling the remote-control key, etc. Use this function to deactivate the vehicle’s transport mode to restore the vehicle to normal operation.



NOTE: The function procedures vary between vehicle makes and models.

1. Select **Transport Mode** on the Workshop Tools screen.

- A “One moment please...” message displays.



NOTE: If *Transport Mode* is not supported for the vehicle under test, an “advisory” message displays. Tap **Exit**, as necessary, to return to the Workshop Tools screen.

- One or more sub-menus will display. Select the desired options, then proceed to **step 2**.

2. One or more “informational/instructional” screens display.

- Perform procedures as directed. Select **On** or **Off**, as appropriate.

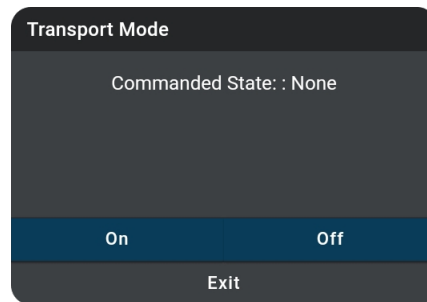

3. For some vehicles, “status” screens display as each phase of the procedure is successfully completed.

- A “results” screen displays when the procedure has been completed.

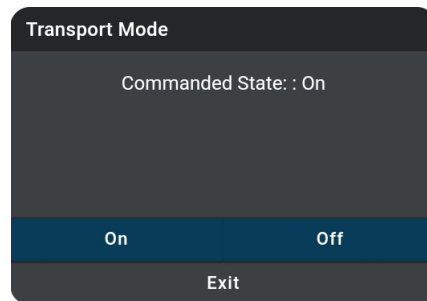

4. Tap **Exit** to close the results message.
5. Tap the ← icon at the top of the page to return to the Workshop Tools screen.

COOLANT BLEEDING

Use this function whenever the coolant or antifreeze fluids are drained and/or refilled. Performing this routine removes any air pockets that may have built up when adding new coolant.



NOTE: The function procedures vary between vehicle makes and models.

1. Select **Coolant Bleeding** on the Workshop Tools screen.

- A “One moment please...” message displays.



NOTE: If *Coolant Bleeding* is not supported for the vehicle under test, an “advisory” message displays. Tap **Exit**, as necessary, to return to the Workshop Tools screen.

- One or more sub-menus will display. Select the desired options, then proceed to **step 2**.
2. One or more “informational/instructional” screens display.
 - Perform procedures as directed. Choose **Next**, as appropriate, to scroll to the next screen.

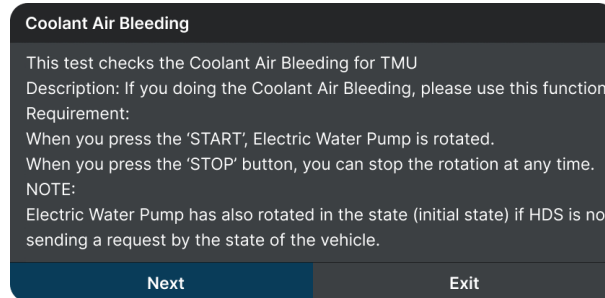

3. Tap **Start** or **Stop** as desired.
 - The screen refreshes to show the result.

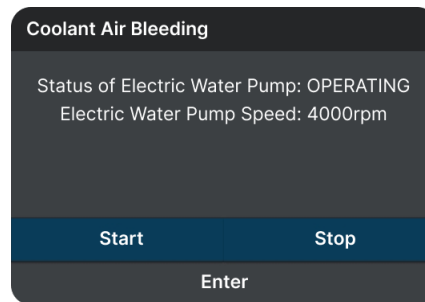

4. Tap **Enter** to finish the function.
 - One or more “instructional” screens will display. Follow the instructions on the screen.
5. Tap **Exit** to close the results message.
6. Tap the ← icon at the top of the page to return to the Workshop Tools screen.

LIMIT SPEED

This function caps a vehicle’s top speed at a preset value, set by the ECU for safety, fleet management, compliance, or specific driving conditions.



NOTE: *The function procedures vary between vehicle makes and models.*

1. Select **Limit Speed** on the Workshop Tools screen.
 - A “One moment please...” message displays.
- 
- NOTE:** *If Limit Speed is not supported for the vehicle under test, an “advisory” message displays. Tap **Exit**, as necessary, to return to the Workshop Tools screen.*
- One or more sub-menus will display. Select the desired options, then proceed to **step 2**.
2. One or more “informational/instructional” screens display.

- Perform procedures as directed. Choose **Next**, as appropriate, to scroll to the next screen.

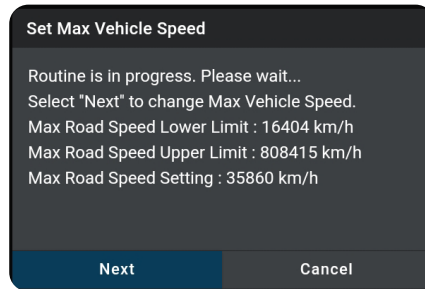

3. Enter **new maximum** vehicle speed, then tap **Next** to continue.

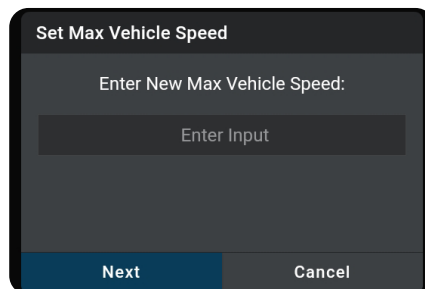

4. A “results” screen displays when the reset procedure has been completed. Tap **Finish** to terminate the procedure.

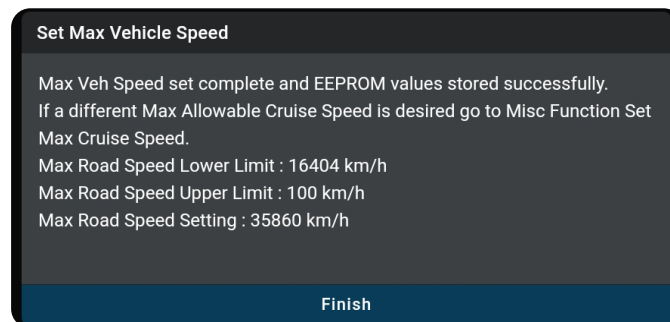

5. Tap the ← icon at the top of the page to return to the Workshop Tools screen.

OXYGEN SENSOR TEST

The oxygen sensor measures exhaust oxygen to help the ECM/ECU adjust the air-fuel mixture for efficient combustion, better performance, and lower emissions.



NOTE: *The function procedures vary between vehicle makes and models.*

1. Select **Oxygen Sensor Test** on the Workshop Tools screen.
 - A “One moment please...” message displays.



NOTE: *If Oxygen Sensor Test is not supported for the vehicle under test, an “advisory” message displays. Tap **Exit**, as necessary, to return to the Workshop Tools screen.*

- One or more sub-menus will display. Select the desired options, then proceed to **step 2**.
2. One or more “informational/instructional” screens display.
 - Perform test procedures as directed. Choose **Next**, as appropriate, to scroll to the next screen.

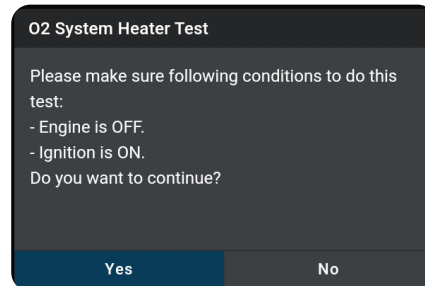

3. Select the option you wish to perform.

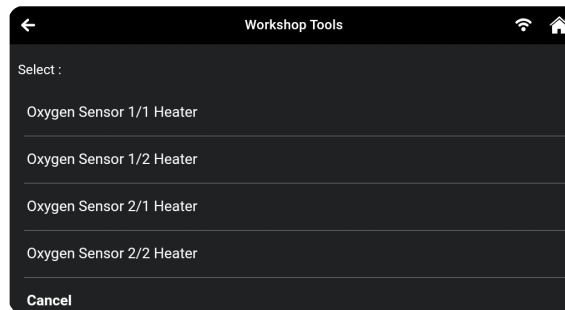

4. A “results” screen displays when the test procedure has been completed. Tap **Finish** to terminate the procedure, or **Next** to continue with other tests.

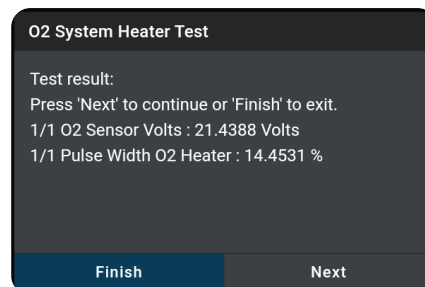

5. Tap the ← icon at the top of the page to return to the Workshop Tools screen.

POWER BALANCE

All engine cylinders should produce equal power, but wear, damage, or faults can cause imbalances, leading to lower performance, higher fuel use, and vibration.



NOTE: *The function procedures vary between vehicle makes and models.*

1. Select **Power Balance** on the Workshop Tools screen.
 - A “One moment please...” message displays.



NOTE: If Power Balance is not supported for the vehicle under test, an “advisory” message displays. Tap **Exit**, as necessary, to return to the Workshop Tools screen.

- One or more sub-menus will display. Select the desired options, then proceed to **step 2**.
2. One or more “informational/instructional” screens display.
- Perform reset procedures as directed. Choose **Start**, as appropriate, to scroll to the next screen.

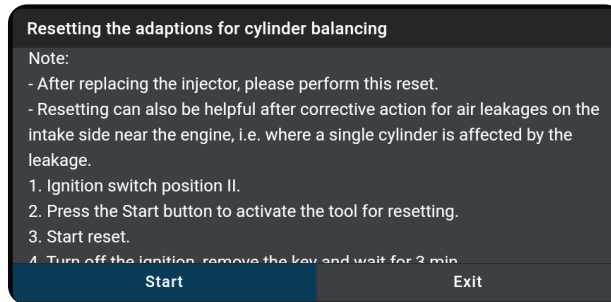

3. A “results” screen displays when the reset procedure has been completed. Tap **Exit** to terminate the procedure.

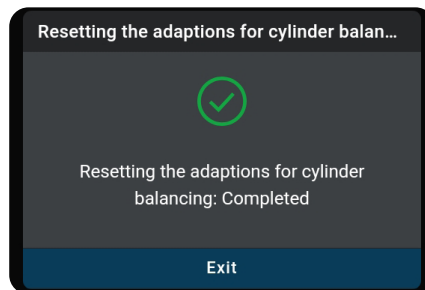

4. Tap the ← icon at the top of the page to return to the Workshop Tools screen.

CALIBRATIONS

STEERING ANGLE SENSOR (SAS) CALIBRATION

The steering angle sensor measures the wheel’s position and turning rate. For accurate ECU calculations, the sensor must be calibrated to the zero point when the vehicle is moving straight.



NOTE: The function procedures vary between vehicle makes and models.

1. Tap **Steering Angle Sensor Calibration** on the Workshop Tools screen.
 - For some vehicles, one or more sub-menus display. Tap the desired **module** and/or **option**, as appropriate. Proceed to **step 2**.

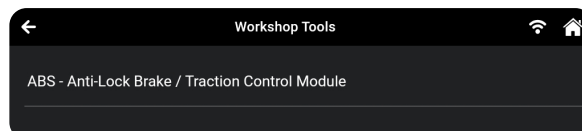



NOTE: If SAS calibration is not supported by the vehicle under test, an “advisory” message displays. Tap **OK** to return to the Workshop Tools menu.

2. A “One moment” message displays, followed by one or more “informational/instructional” screens.

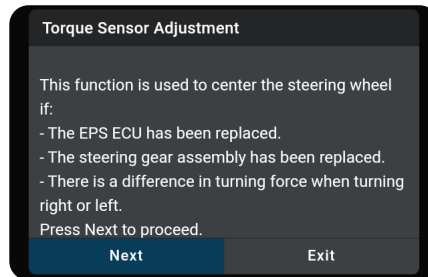

- Perform calibration procedures as directed. Tap **Next** or **Continue**, as appropriate, to scroll to the next screen, or, tap **End** or **Exit** to terminate the procedure.
3. For some vehicles, “status” screens display as each phase of the calibration procedure is successfully completed. Tap **Next**, as appropriate, to scroll to the next screen.
 - A “results” screen displays when the calibration procedure has completed.

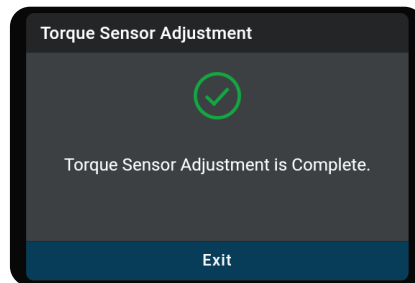

4. Tap **End** or **Exit**, as appropriate, to return to the Steering Angle Sensor Calibration menu.
5. Tap the ← icon at the top of the page to return to the Workshop Tools screen.

SUSPENSION CALIBRATION

Use this function to reset the height for the vehicle’s four suspensions on each wheel when the heights are different, or after replacing the vehicle height sensor or control module in the vehicle’s air suspension system.



NOTE: The function procedures vary between vehicle makes and models.

1. Select **Suspension Calibration** on the Workshop Tools screen.
 - A “One moment please...” message may display.



NOTE: If Suspension Calibration is not supported for the vehicle under test, an “advisory” message displays. Tap **Exit**, as necessary, to return to the Workshop Tools screen.

- One or more sub-menus will display. Select the desired options, then proceed to **step 2**.

2. One or more “informational/instructional” screens display.



- Perform calibration procedures as directed. Choose **Next** or **Continue**, as appropriate, to scroll to the next screen.
3. For some vehicles, “status” screens display as each phase of the calibration procedure is successfully completed. Choose **Next** or **Continue**, as appropriate, to scroll to the next screen.
 - A “results” screen displays when the calibration procedure has been completed.



4. Tap **Exit** to close the results message.
5. Tap the ← icon at the top of the page to return to the Workshop Tools screen.

HEADLAMP CALIBRATION

Calibration is required in most cases after installing a new headlamp capsule or replacing the sensors and modules used to operate the headlamps. This function allows you to adjust the ride height to the manufacturer’s recommended specifications.



NOTE: *The function procedures vary between vehicle makes and models.*

1. Select **Headlamp Calibration** on the Workshop Tools screen.

- A “One moment please...” message may display.



NOTE: *If Headlamp Calibration is not supported for the vehicle under test, an “advisory” message displays. Tap **Exit**, as necessary, to return to the Workshop Tools screen.*

- One or more sub-menus will display. Select the desired options, then proceed to **step 2**.
2. One or more “informational/instructional” screens display.

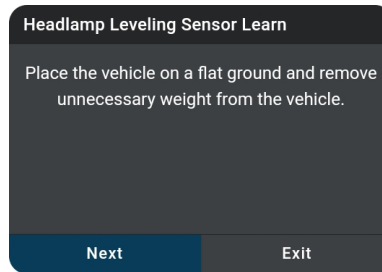

- Perform calibration procedures as directed. Choose **Next** or **Continue**, as appropriate, to scroll to the next screen.
3. For some vehicles, “status” screens display as each phase of the calibration procedure is successfully completed. Tap **On**, **Off** or **Start** as desired, to perform the function.
 - A “results” screen displays when the calibration procedure has been completed.

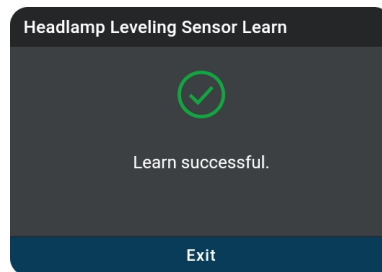

4. Tap **Exit** to close the results message.
5. Tap the ← icon at the top of the page to return to the Workshop Tools screen.

OCCUPANT SEAT SENSOR CALIBRATION

Use this function to reset or calibrate the vehicle's seat sensors after making repairs after an accident or seat service routine. This feature helps set the zero point for the passenger seat.



NOTE: *The function procedures vary between vehicle makes and models.*

1. Select **Occupant Seat Sensor Calibration** on the Workshop Tools screen.
 - A “One moment please...” message may display.



NOTE: *If Occupant Seat Sensor Calibration is not supported for the vehicle under test, an “advisory” message displays. Tap **Exit**, as necessary, to return to the Workshop Tools screen.*

- One or more sub-menus will display. Select the desired options, then proceed to **step 2**.
2. Perform calibration procedures as directed. Select **On** or **Off**, as appropriate.

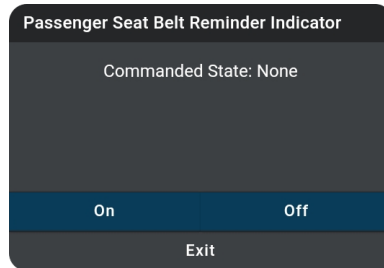

3. For some vehicles, "status" screens display as each phase of the calibration procedure is successfully completed.
 - The screen refreshes to show the result.

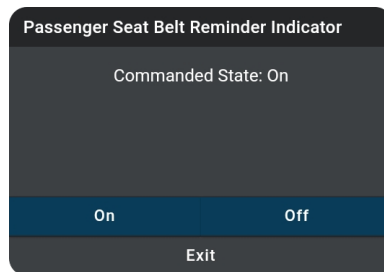

4. Tap **Exit** to close the results message.
5. Tap the ← icon at the top of the page to return to the Workshop Tools screen.

CONFIGURATIONS

VIN READ/WRITE

This function lets technicians enter or update the Vehicle Identification Number in the ECM, ensuring it matches the vehicle's configuration for proper servicing and maintenance.



NOTE: *The function procedures vary between vehicle makes and models.*

1. Tap **VIN Read/Write** on the Workshop Tools screen.
 - For some vehicles, one or more sub-menus display. Tap the desired **module** and/or **option**, as appropriate. Proceed to **step 2**.



NOTE: *If VIN Read/Write is not supported by the vehicle under test, an "advisory" message displays. Tap **OK** to return to the Workshop Tools menu.*

2. A "One moment please..." message displays, followed by one or more "informational/instructional" screens.
 - Perform procedures as directed. Tap **Next** or **Continue**, as appropriate, to scroll to the next screen, or, tap **Back** or **Exit** to terminate the procedure.
3. Enter the new VIN, then tap **Next** to continue.

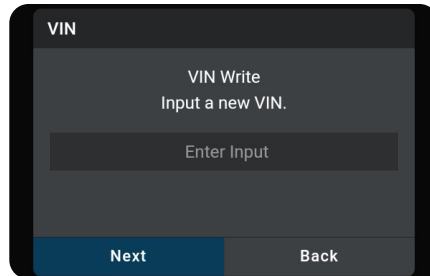

4. A “results” screen displays when the procedure has completed.

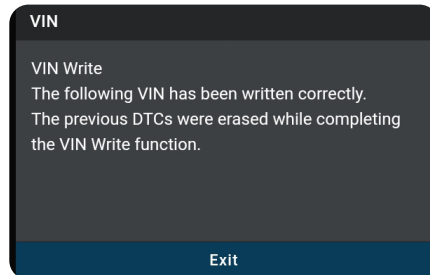

5. Tap **Exit** to close the results message.
6. Tap the ← icon at the top of the page to return to the Workshop Tools screen.

ECU CODING

This function allows modification of specific ECU settings, enabling customization and the activation or deactivation of certain features, all without altering the ECU’s core software.



NOTE: *The function procedures vary between vehicle makes and models.*

1. Tap **ECU Coding** on the Workshop Tools screen.
 - For some vehicles, one or more sub-menus display. Tap the desired **module** and/or **option**, as appropriate. Proceed to **step 2**.
2. One or more “informational/instructional” screens display. Tap **Next** or **Enter** to continue.

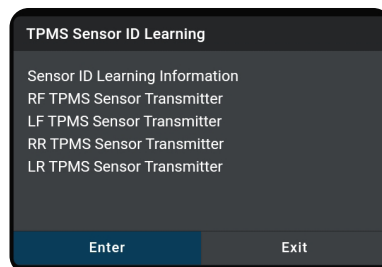

- The “One moment please...” message displays when the procedure is in process.
3. A “results” screen displays when the procedure has been completed.

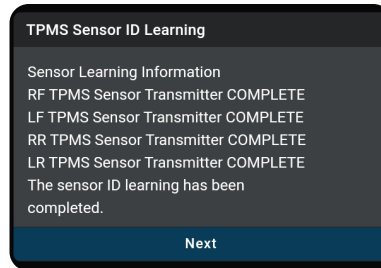

4. Tap **Next** to close the results message.
5. Tap the ← icon at the top of the page to return to the Workshop Tools screen.

FAVORITES FUNCTIONS

The Favorites function lets you pin frequently used Workshop Tools for quick and easy access.

1. From the Home screen, tap **Workshop Tools**.
 - The Workshop Tools screen displays.
2. Scroll the **Workshop Tools** page, then tap the + icon in the Favorites section.

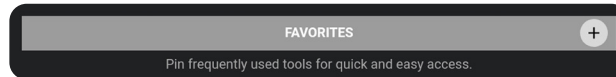

3. Select the checkbox for the function you want to pin to the Favorites section, then tap **DONE**.

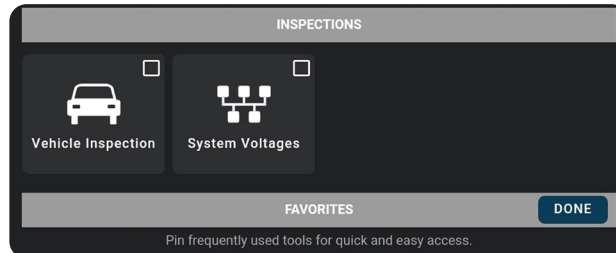

4. Once completed, the Favorites functions are pinned to the top of the Workshop Tools screen.

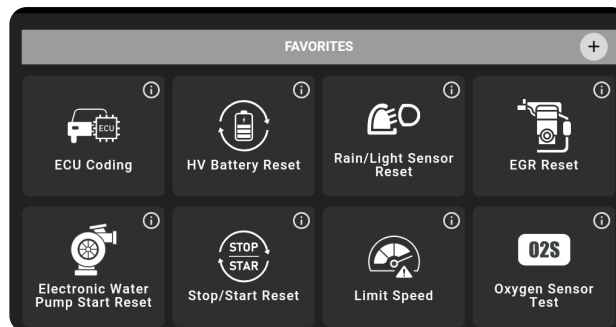

PREVIOUS VEHICLES

The INNOVA® Smart Diagnostic System permanently stores the results of the most recent vehicle scans you have performed. The **PREVIOUS VEHICLES** tab allows you to retrieve these historical scan records and view them as needed. The page includes two options: **Scan History** and **Live Data**.



SCAN HISTORY REPORTS

Entries on the **Scan History** tab are listed in reverse chronological order (most recent scan first). Each entry in the list provides the following information:

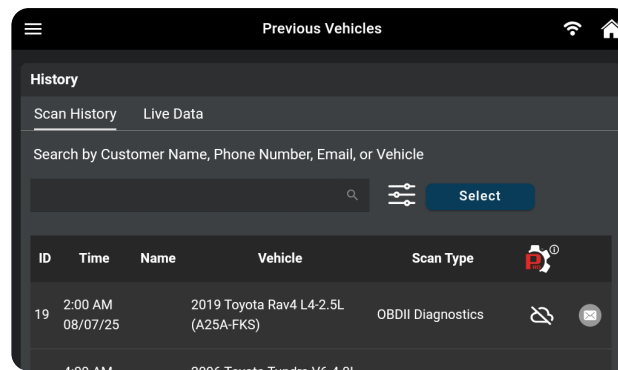

- **Search Bar** – Tap the search bar to enter a search criterion – Customer Name, Phone Number, Email or Vehicle.
- **ID** – The auto-generated reference report number for the scan.
- **Time** – The date and time at which the scan was performed.
- **Name** – The name of the customer, if provided [[See page 38](#)].
- **Vehicle** – The year, make, model, trim and engine size of the tested vehicle.
- **Scan Type** – Identifies if the scan was an **OBD II Diagnostics** scan [[See page 17](#)], an **OEM Diagnostics** scan [[See page 40](#)] or **Vehicle Inspection** scan [[See page 50](#)].
- – Indicates the status of the report upload to the RSPRO® app.
 - – Indicates that the report has been successfully uploaded to the RSPRO® app.
 - – Indicates that the report has not been uploaded to the RSPRO® app.
- **Email icon** – Allows you to email the associated report. A gray color indicates that the report has not been sent, while a green color indicates that the report was successfully sent.

DELETE THE HISTORY REPORTS

1. Tap the **Select** button.
2. Select the checkbox of the report you wish to delete, then tap the **Delete** icon.

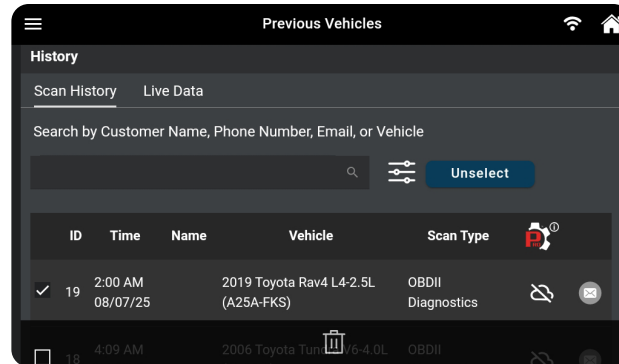



3. The “confirmation” screen displays. Tap **Continue**.
4. Once completed, the success message displays.

VIEWING SCAN HISTORY REPORTS

1. Tap an entry on the **Scan History** tab.
2. The report view differs based on the *Scan Type* listed on the entry:
 - **OBD II Diagnostics** – the OBD II Diagnostic test result screen displays. [\[See page 17\]](#)
 - **OEM Diagnostics** – the Scan All Systems test result screen displays. [\[See page 40\]](#)
 - **Vehicle Inspection** – the Vehicle Inspection Report test result screen displays. [\[See page 50\]](#)
 - Navigate as usual to view the report.

EMAILING & PRINTING REPORTS

The Scan History report results lets you email a PDF version of the report to a customer or yourself.

1. Tap the  email icon at the end of the entry.
 - If the  email icon is missing:
 - Tap the entry for the report you wish to send.
 - Scroll to the “*Fix for DTC*” section.
 - Tap the **Tap For Details** button to generate the report.
 - Tap the  **Menu** icon and tap **Previous Vehicle** to return to the Scan History tab.
2. The Vehicle Diagnostic Report entry dialog displays.

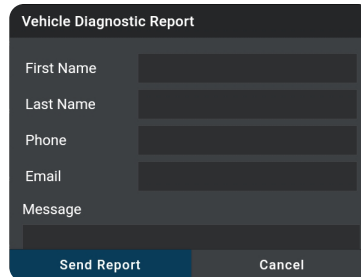

Vehicle Diagnostic Report

First Name

Last Name

Phone



Email

Message

Send Report Cancel

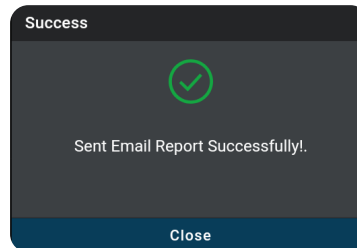
3. Enter the recipient's information.
 - Be sure to use a properly formatted Email address (*Example: yourname@gmail.com*).
4. Tap the **Send Report** button to proceed; or tap **Cancel** to exit.
 - A "confirmation" dialog displays.



5. Tap **Close** to finish and exit.
 - The email icon turns from  "gray" to  "green" when a report is sent.
6. The recipient receives an email with a PDF copy of the report, which can be saved and printed.

PLAYBACK RECORDED LIVE DATA

Entries on the **Live Data** tab are listed in reverse chronological order (*most recent recording first*). Each entry in the list provides the following information:

- **Date** – The date on which the recording was made.
- **Time** – The time at which the recording was made.
- **Vehicle** – The year, make, model and engine size of the vehicle for which the recording was made.

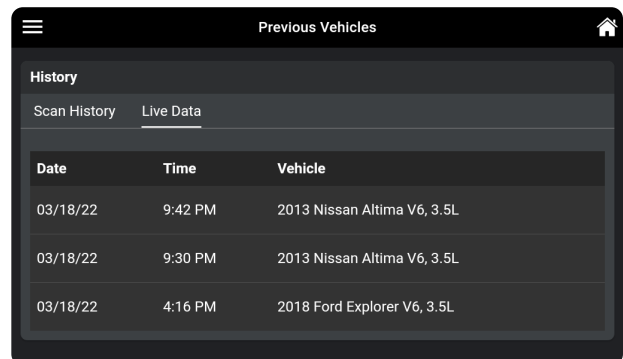

Previous Vehicles

History

Scan History Live Data

Date	Time	Vehicle
03/18/22	9:42 PM	2013 Nissan Altima V6, 3.5L
03/18/22	9:30 PM	2013 Nissan Altima V6, 3.5L
03/18/22	4:16 PM	2018 Ford Explorer V6, 3.5L



To View & Playback Recorded Live Data:

1. Tap the **Live Data** tab to view all recorded entries.
2. Tap an entry on the Live Data tab to play back recorded data.

- A loading Live Data dialog displays.
3. Tap **Play** to start the playback.
 - If desired, use the **View Table** and **View Graph** buttons to toggle the display between graph mode and tabular mode during playback.
 - In the **View Table** mode, tap **Unselect Parameters** to unselect all mode parameters, or tap on each individual parameter to “**select**” and “**unselect**” each parameter you wish to view during playback.

4. Tap **Pause** to pause the playback.

5. Tap **Stop** to stop the playback.

6. To exit, tap the  icon to return to the Previous Vehicle main screen, or the  **Home** icon to return to the Home screen.

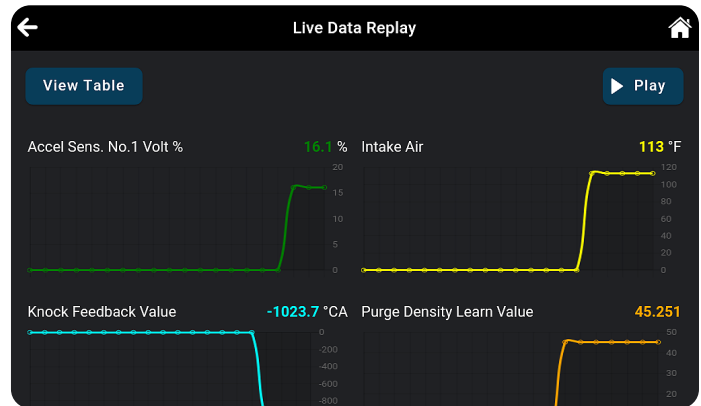

SETTINGS

The **SETTINGS** tab lets you customize several personal preferences including retailer selection, Wi-Fi, language, and other options. In addition, you can contact technical support, and report any issues.



To enter the Settings mode:

1. Tap the **SETTINGS** tab on the Home screen to access the Settings page.
 - You can also access this page by tapping the **Menu** icon in the upper left corner of the page and tapping **Settings**.
 - The Settings page displays.

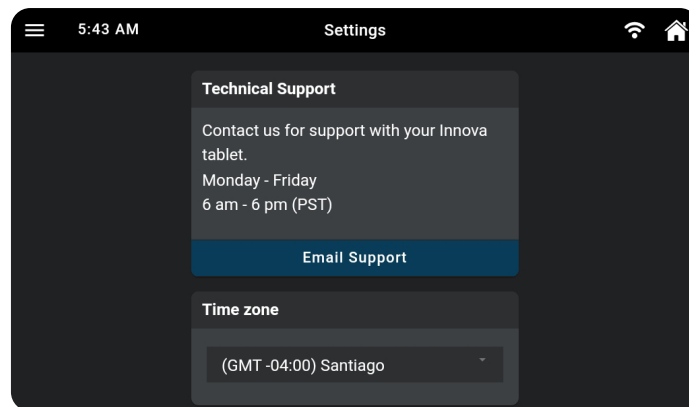

2. Swipe up or down to scroll to the desired option.
3. Make adjustments and settings as outlined in the following pages.

To exit the Settings mode:

- Tap the **Menu** icon on the top left to open the Menu panel and make another selection.
- Tap the **Home** icon on the top right to return to the Home screen.

TECHNICAL SUPPORT (Send an Email)

The Innova Electronics technical team is here to help if you encounter any issues or if you have any questions. You can reach them directly with the tablet **Monday through Friday, 6:00AM to 6:00PM, Pacific Time**.

To connect with Technical Support:

1. From the Home screen, tap **SETTINGS**. (You can also access Settings from the **Main Menu** by tapping **Settings**.)
 - The Settings screen displays.
2. Tap **Email Support**.

- The Support by Email dialog displays.

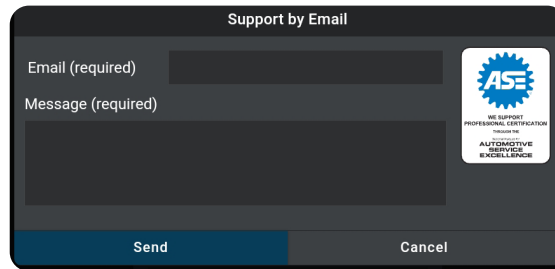

- The Email field shows the most recently entered email address for the tablet. If no address was previously entered, the Email field shows an empty text box.



NOTE: You *MUST* provide a personal email address to receive a reply from Innova Technical Support via email.

3. To enter an **Email** address for the first time:
 - Tap the **Email** text box, then enter your personal email address.
4. To change an existing **Email** address:
 - Tap **Change**. The current Email address displays in an editable text box.
5. Tap the **Send** button to send your email to Innova Technical Support.
 - To cancel your message without sending, tap **Cancel** to return to the Technical Support dialog.
 - A “confirmation” message displays. Tap **Close** to close the message.

DATE AND TIME SETTINGS

Here you can set the current date and time for the tablet.

1. From the Home screen, tap **SETTINGS**. (You can also access Settings from the ≡ Main Menu by tapping ⚙ **Settings**.)
 - The Settings screen displays.
2. Scroll the **Settings** page.
 - If the tablet is connected to the internet, the **Time zone** field is displayed. Proceed to **step 3**.
 - If the tablet is not connected to the internet, the **Date and Time Settings** field is displayed. Proceed to **step 4**.
3. With an internet connection, the tablet will display a world clock. You can change the date and time by selecting the desired Time zone.

Time zone

(GMT -08:00) Pacific Time (US & ...

- Select the desired Time zone, then tap the **OK** button.
4. Without an internet connection, you can manually set the date and time.

Date and Time Settings

03/31/2024

11:22 pm

Set Date and Time

- To specify the current date:
 - Tap the **date format** field. The Set Date dialog displays.
 - Scroll through the “month”, “day”, and “year” fields to set the current calendar date, then tap **Done**. Click **Cancel** to close the Set Date dialog and retain the previous date.
 - To specify the current time:
 - Tap the **time format** field. The Set Time dialog displays.
 - Scroll through the “hour”, “minute”, and “am/pm” fields to set the current time, then tap **Done**. Tap **Cancel** to close the Set Time dialog and retain the previous time.
5. Tap the **Set Date and Time** button to save your changes.
- A “confirmation” message displays. Tap **Close** to close the message.



NOTE: When the tablet connects to the internet again, the custom date and time will be updated according to the Time zone selected beforehand.

VEHICLE INSPECTION SETUP

The Vehicle Inspection Setup feature is designed to provide users with the ability to create various report types. Vehicle Inspection reporting includes three report types: **Diagnostic Report**, **Customer Report**, and **Collision Industry Report**. In each report type, the user has the flexibility to customize their inspection report according to their unique requirements, such as OBD II Diagnostics, Scan All Systems, Service Check, and Service Warning Light. This customizable vehicle inspection setup allows the reporting to be tailored to specific functions that you select, whether it's routine maintenance, diagnostic analysis, or collision repairs.

1. Scroll the Settings page to the **Vehicle Inspection Setup** field.

Vehicle Inspection Setup

Diagnostic Report Setup >

Customer Report Setup >

Collision Industry Report Setup >

2. Tap the business report you wish to set up.
 - The Report selection screen displays.
 - Tap a checkbox to turn the associated feature on or off as desired.
3. Tap the **Save** button to save your changes.
 - Tap the **Cancel** button to close the screen without saving any changes.

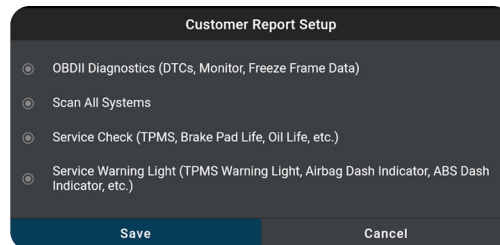

RSPRO SETTINGS

You have the option and convenience of purchasing the associated part(s) for each recommended fix. Each part includes a button, which links to your selected retailer and provides an estimated cost. This feature can be turned on and off as desired. To get the best possible parts recommendations, provide the name of the retailer where you purchased your INNOVA Smart Diagnostic System tablet.

1. Scroll the Settings page to the **RSPRO Settings** field.
2. Tap the **Toggle Switch** to either turn On or Off the Buy Parts feature.

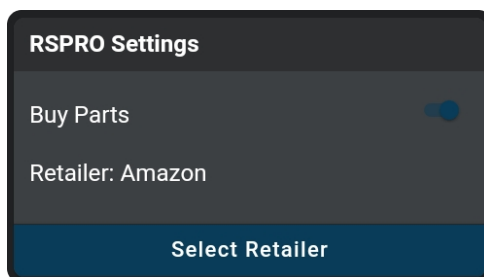

3. If you previously specified a retailer, the name of the retailer is shown.
4. Tap **Select Retailer**.
 - The Select Retailer dialog displays.
5. Tap the **Enter Retailer** text box, then enter the name of the location from which you purchased your tablet (or another local retailer, as desired) using the keyboard.

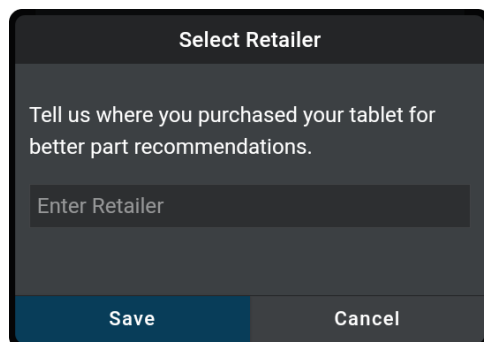

- When the desired retailer has been entered, tap the **Save** button to save your changes and return to the Retailer field.
 - To cancel changes and retain the current retailer, tap **Cancel** to return to the Retailer field.

MOTOR PLAN INFORMATION

You can view details about your current MOTOR plan.

- Scroll the Settings page to the **MOTOR Plan Information** field.

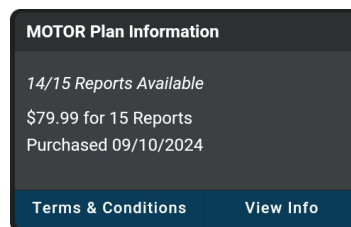

- The tablet displays information about your plan, including the available reports and purchase date.
 - Tap **Terms & Conditions** to view the Terms of Use and End User License Agreement.
 - Tap **View Info** to access detailed plan information.
- Motor Information is provided for a duration of one month per Confirmed/MIL DTC and VIN. If the same VIN and Confirmed/MIL DTC are scanned again within this one month, no additional fees are charged. Additionally, if you have remaining report credits, they will not be deducted.

WI-FI SETTINGS

To access all the features provided in your diagnostic tablet, a local Wi-Fi network connection is necessary.

Connecting to a Wi-Fi Network

- Scroll the Settings page to the **Wi-Fi Settings** field.
 - If you are currently connected to a Wi-Fi network, the network name is shown; if not, it shows "Not Connected".

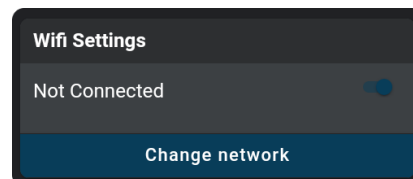

- Tap **Change Network**.
 - The Sign In To Your Wi-Fi Network dialog displays.
 - The dialog lists all available Wi-Fi networks within range of the tablet.

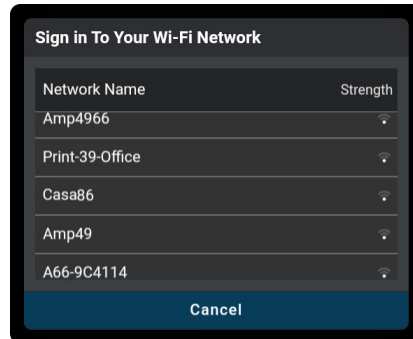

3. Swipe up or down to scroll to the desired Wi-Fi network, then tap the network name.
 - To cancel changes and retain the current network connection, tap **Cancel** to return to the Wi-Fi Settings field.
 - The Enter Password dialog displays.
4. Tap the **Password** text box, then enter the Wi-Fi network password using the keyboard.

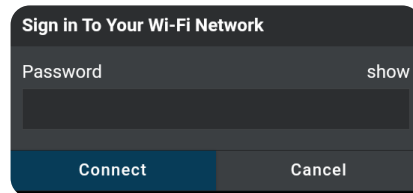

- As you type, the password displays as a series of bullets by default. Tap **show** to show the password as you type. Tap **hide** to display the password as bullets.
5. When the password has been entered, tap the **Connect** button to save your changes and connect to the selected Wi-Fi network.
 - Tap **Cancel** to cancel your changes and return to the Sign In To Your Wi-Fi Network dialog to select a different network.

SMOG CHECK OR I/M PROGRAM LOCATION

Allows you to set the Smog Check or I/M Program Location to enhance the emission readiness logic.

Configuring Smog Check or I/M Program Location:

1. Scroll the Settings page to the **Smog Check or I/M Program Location** field.

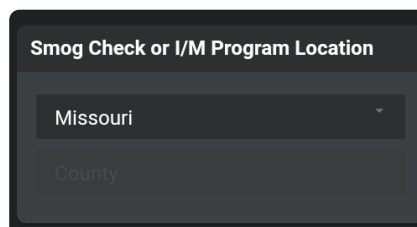

2. Tap the **radio button** for the desired U.S State, then tap **OK**.
 - Tap **Cancel** to close the menu and retain the previously selected location.
3. In some states, county-specific logic may be required. If your state requires this additional logic, select the desired county by clicking the corresponding radio button.

REGIONAL SETTINGS

This function lets you set the unit of measurement for the tablet's display to US Standard or Metric.

Configuring Regional Settings

1. Scroll the Settings page to the **Regional Settings** field.

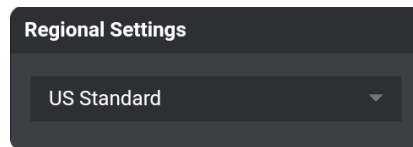

2. Tap the currently selected unit of measurement to display the menu. Select the radio button for the desired unit of measurement, then tap **OK**.
 - Tap **Cancel** to close the menu and retain the previously selected unit of measurement.

LANGUAGE

This function lets you set the display language for the tablet to either English, Spanish or French.

Setting the Display Language

1. Scroll the Settings page to the **Language** field.

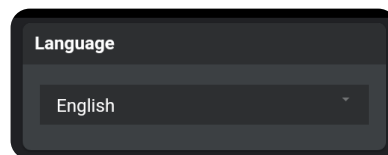

2. Tap the currently active language to display the Select Language menu. Select the radio button for the desired language, then tap **OK**.
 - Click **Cancel** to close the Select Language menu and retain the previously selected display language.
 - The display refreshes to show text in the selected language.

IDLE TIME SETTINGS

Lets you set the length of "idle" time before the tablet enters "standby" mode.

Idle Time Settings

1. Scroll the Settings page to the **Idle Time Settings** field.

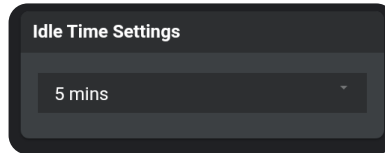

2. Tap the currently active idle time value to display the Select Idle Time menu. Select the radio button for the desired idle time value, then tap **OK**.
 - Tap **Cancel** to close the Select Idle Time menu and retain the previously selected idle time value.

AUTO SHUT OFF

Lets you set a specified time to automatically shut off the tablet.

1. Scroll the Settings page to the **Auto Shut Off** field.

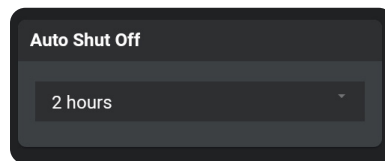

2. Tap the **currently active time value** to display the Auto Shut Off menu. Select the **radio button** for the desired time value, then tap **OK**.
 - Tap **Cancel** to close the Auto Shut Off menu and retain the previously selected time value.

VOLUME SETTINGS

Sets the volume level of the tablet speaker.

Adjusting Speaker Volume

1. Scroll the Settings page to the **Volume Settings** field.

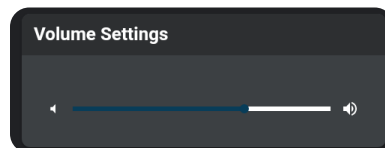

2. Use the Volume "slider" to increase or decrease speaker volume:
 - Touch and slide right to make the volume louder.
 - Touch and slide left to make the volume softer.
 - The current Volume setting shows above the slider as you adjust the slider position.

BRIGHTNESS SETTINGS

Lets you adjust the brightness of the display screen.

Adjusting Display Brightness

1. Scroll the Settings page to the **Brightness Settings** field.
2. Use the Brightness “slider” to increase or decrease display brightness:

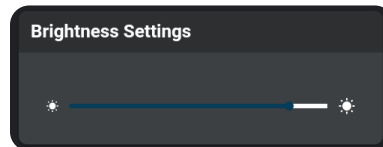

- Touch and slide right to make the display brighter.
- Touch and slide left to make the display darker.
 - The current Brightness setting shows above the slider as you adjust the slider position.

THEME SETTINGS

Lets you to change the appearance of the tablet screens.

Changing Theme Settings

1. Scroll the Settings page to the **Theme Settings** field.
 - Tap the **Light** selection to make the tablet’s screen contrast to white / brighter mode.
 - Tap the **Dark** selection to make the tablet’s screen contrast to dark gray / darker mode.

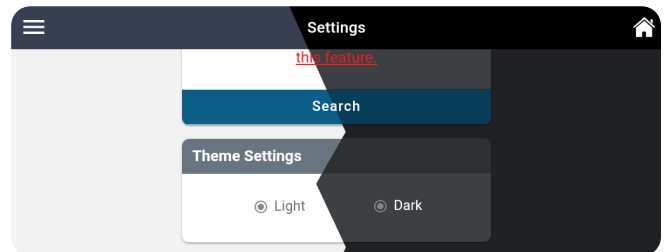

RSPRO ACCOUNT INFORMATION

Create, access, and edit your RepairSolutionsPRO® account.

CREATE AN ACCOUNT

1. Tap **Settings** on the Home screen and scroll down to the “RSPRO Account Information” section.
2. Tap the **Create an Account** button to begin.
3. Complete the displayed form with your name, email address, your desired password, and other personal information.

- Select the **Business Info** form and provide your business name, phone number, address, and additional business information.
4. Complete your registration by **reviewing the terms** and tap the **Create Account** button at the bottom of the form.
 - The confirmation message “The account has been created successfully” displays. If properly signed in, the Account Information screen displays your account name and email.

EDIT ACCOUNT INFORMATION

Allows you to change your password and other personal information.

1. Tap **Settings** on the Home screen and scroll down to the “RSPRO Account Information” section.
2. Make any necessary changes as desired and tap the **Save Changes** button to confirm your edits.

ACCOUNT LOG IN

1. Tap **Settings** on the Home screen and scroll down to the “RSPRO Account Information” section.
2. Tap the **Log In** button.
 - The RSPRO “Log In” dialog displays.
3. Enter your credentials and tap the **Login** button.

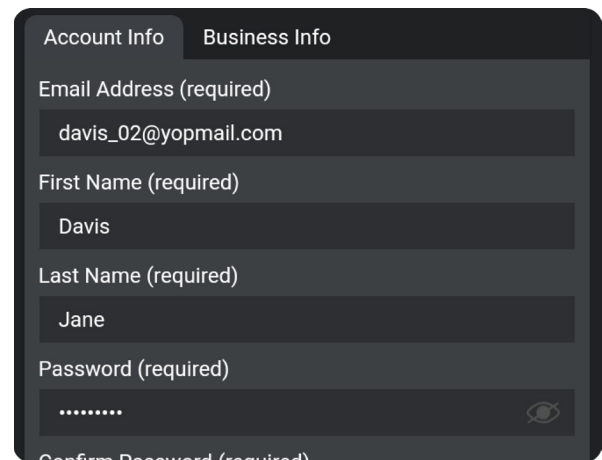

RESET ACCOUNT PASSWORD

1. Tap **Settings** on the Home screen and scroll down to the “RSPRO Account Information” section.
2. Tap the **Log In** button.
 - The RSPRO “Log In” dialog displays.
3. Tap **Forgot password** and follow the prompts.

VERSION INFORMATION

The Version Information field shows the tablet’s Software Version, Tool Version, and other related specifications. This screen also lets you check for software updates or report an issue with the tablet.

Viewing the “Version Information”

1. Scroll the Settings page to the **Version Information** field.
 - The field shows the current **Software Version**, **Tool ID**, **firmware version (FW)**, **database version (DB)**, **bootloader version (BL)**, **GUID/Serial Num**, **Android Version** and **Build Number** for the tablet.
-

2. Tap **View Release Notes** to see what was updated with the current version.
3. Tap **Check for Updates** to check and download any updates.
 - The tablet verifies an Internet connection and checks for any updates. If an update is available, you are given the option to view the release notes, update the tablet, or enable an update reminder.



NOTE: If the tablet is connected to the Internet and an update is available, the tablet will automatically display an update notification dialog on the Home screen. If presented, simply tap the **More Info** button to proceed, or tap the **Remind Me Later** button to update at a later time.



REPORT AN ISSUE

Did you encounter an OBD II connection issue or a DTC-specific problem? Use this feature to record a log of the issue and send a direct message to Innova's Technical Team to get support.

To report an issue:

1. Scroll to the Report an Issue field.
2. Tap the **Report an Issue** button.
 - A selection page displays.
3. Tap the type of issue you wish to report; **OBD II**, **ECM DTC**, **ABS DTC** or **SRS DTC**.

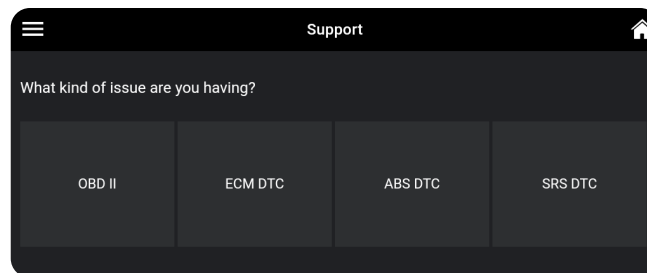

- An "instructional" dialog displays.

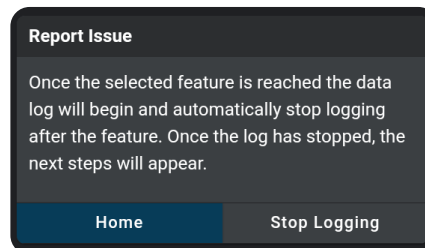

4. Tap the **Home** button to begin.
 - The display returns to the Home Page, and the red **Data Log On** icon displays in the lower left corner of the screen.

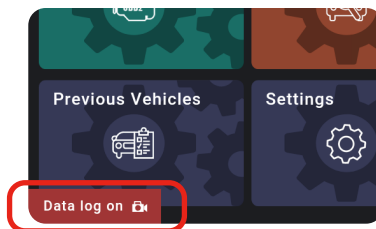

5. Proceed to perform the steps you took to demonstrate where you encountered the issue.
6. Tap the **Data Log On** icon to return to the instructional dialog.
7. Tap the **Stop Logging** button.
 - A dialog screen displays with the vehicle's information and tablet information.
8. Enter your Email, Phone, and Issue Description (these are required fields).

 A screenshot of a 'Report Issue' dialog box. It is divided into two columns: 'Vehicle Information' and 'Tool Information'. The 'Vehicle Information' column contains: '2010 Mitsubishi Outlander', 'VIN: JA4JT3AX6AZ603017', 'App: 0.1.82', 'Email: demo@gmail.com', and a '(Change)' link. The 'Tool Information' column contains: 'Firmware: V19.02.04', 'Bootloader: V19.01.05', 'Database: V19.06.11', and 'Phone:'. At the bottom, there are 'Submit' and 'Cancel' buttons.

- If an email is displayed, tap **(Change)** to enter a new email address.
9. Tap **Submit** to send your report, or **Cancel** to exit and return to the Home screen.

FACTORY RESET

1. Scroll to the Factory Reset field.

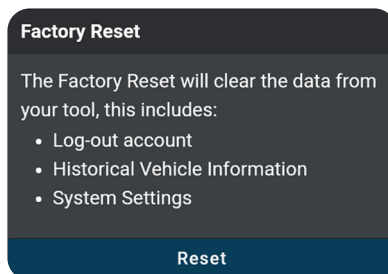

2. Tap the **Reset** button.
 - A "confirmation" screen displays.
3. Tap the **Continue** button.
4. The tablet begins the reset process. Once completed, the tablet returns to the Initial Set Up screen. [[See page 11](#)]

SUPPORT

The **SUPPORT** tab includes various support resources, including:

- **Tool Library** – Access tool definitions and terminology.
- **DLC Locator** – Find the location of the Data Link Connector (DLC) for a specified vehicle.
- **User's Manual** – Access to the most current version of the tablet User's Manual.
- **Tutorials** – Offers detailed instructions on how to use the various scanning application functions.
- **Technical Support** – Directly connect with Innova's Technical Support team via the tablet's email function.
- **Demo Mode** – Provides a step-by-step demonstration of diagnostics operation without connecting to a vehicle.

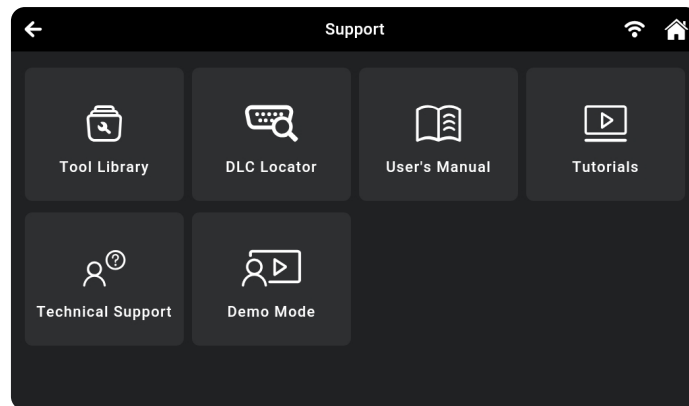

TOOL LIBRARY

Accesses definitions of tablet icons and Diagnostic Trouble Codes (DTCs).

Using the Tool Library:

1. From the Home screen, tap **SUPPORT**. (You can also access it from the **≡ Main Menu** by tapping **Support**.)
 - The Support selection dialog displays.
2. Tap the **Tool Library** button.
 - The Tool Library dialog displays.
3. Select from the provided options.
 - Tap **Cancel** to return to the Support dialog screen.

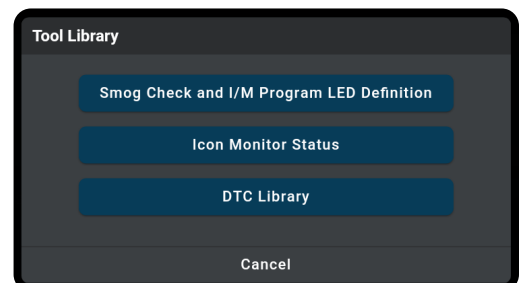

SMOG CHECK OR I/M PROGRAM LED DEFINITION

1. Tap the **Smog Check or I/M Program LED Definition** button.

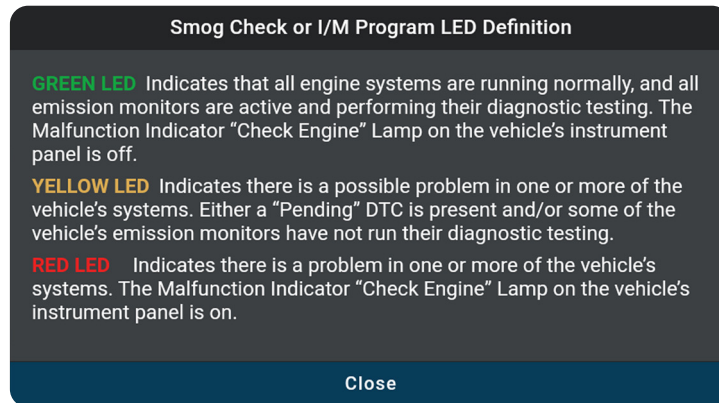

- The Smog Check or I/M Program LED Definition dialog displays.
2. Tap **Cancel** to return to the Tool Library selection screen.

ICON MONITOR STATUS

Defines the Monitor status icon color coding and provides tips on how to proceed.

1. Tap the **Icon Monitor Status** button.
 - The Icon Monitor Status dialog displays.
2. Tap **Cancel** to return to the Tool Library selection screen.

DTC LIBRARY

Searches the Diagnostic Trouble Code (DTC) definitions for most 1996 and newer vehicles.

1. Tap the **DTC Library** button.
 - The DTC Library dialog displays.

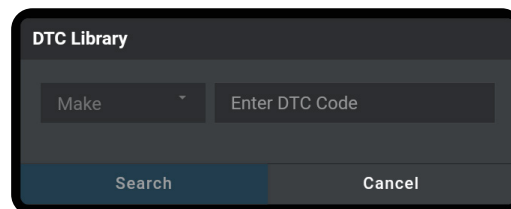

2. Tap **Make** and scroll to select the vehicle's make from the pull-down menu.
3. Tap the **Enter DTC Code** box, then enter the numeric DTC you want to view using the keyboard.
 - Be sure to include all characters – letters and numbers.
4. Tap **Search** to begin the search.

- The search dialog displays with the retrieved definition.
5. Tap **Cancel** to return to the Tool Library selection screen.

DLC LOCATOR

Use this function to quickly find the location of the Data Link Connector (DLC) for a specified vehicle.

USING THE DLC LOCATOR

1. Tap the **DLC Locator** button.
 - The DLC Locator screen displays.

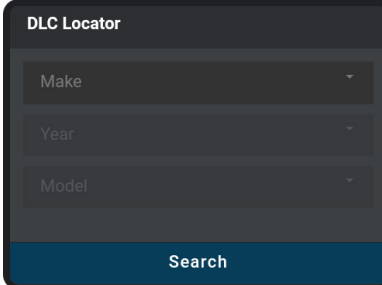

2. Tap **Make** to display the **Select Make** menu.

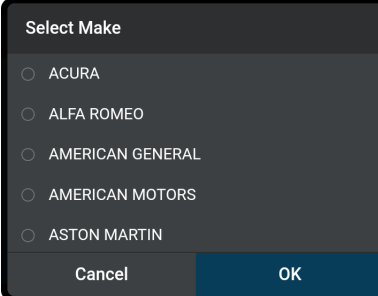

- Select the radio button for the desired vehicle manufacturer, then tap **OK**.

3. Tap **Year** to display the **Select Year** menu.

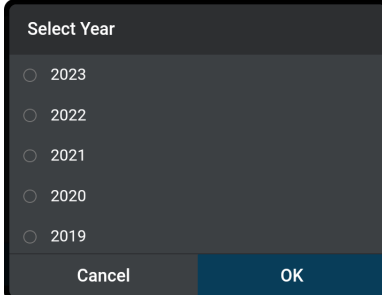

- Select the radio button for the vehicle model year, then tap **OK**.

4. Tap **Model** to display the **Select Model** menu.

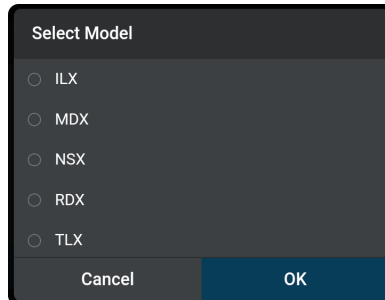

- Select the radio button for the desired vehicle model, then tap **OK**.
5. Tap the **Search** button.
 - The DLC Locator screen for the selected vehicle displays.

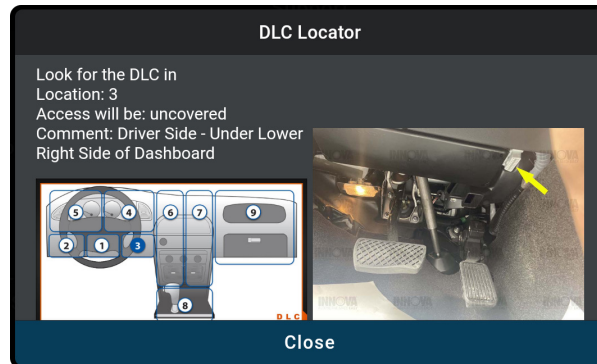

- The DLC Locator screen shows a description of the DLC location and whether the DLC is “covered” or “uncovered,” and includes a picture of the DLC location.
6. Tap the **Close** button to close the DLC Locator screen and return to the Support page.

COMMON DLC LOCATIONS

- **Beneath the Dashboard:** The DLC is often found below the dashboard, near the steering wheel, or the driver’s side footwell. It may be covered by a plastic panel or a flip-up cover that conceals the connector.
- **Left Side of the Steering Column:** Check the area around the left side of the steering column, close to the lower portion of the dashboard.
- **Near the Fuse Box:** In some vehicles, the DLC may be located near the fuse box.
- **Driver’s Side Kick Panel:** Look near the driver’s side kick panel (the plastic panel beside the pedals) as it’s another common location for the DLC.
- **Center Console:** In a few cases, the DLC may be located in the center console area, beneath the radio or climate control unit.
- **Driver’s Side Door Jamb:** Check the area near the driver’s side door jamb or the area surrounding the parking brake.

VIEW USER'S MANUAL

Get access to the most current version of the tablet User's Manual.

Viewing the User's Manual:

1. Tap the **User's Manual** button.
2. Tap **View** to download and view a PDF version of the tablet's most current User's Manual.

TUTORIALS

This Tutorial offers detailed instructions on the various scanning application functions included with the tablet. Take a moment to familiarize yourself with each function to maximize its use and application.

Using the Tutorials:

1. From the Home screen, tap **SUPPORT**.
 - The Support selection dialog displays.
2. Tap the **Tutorials** button.
 - The Tutorials screen displays.

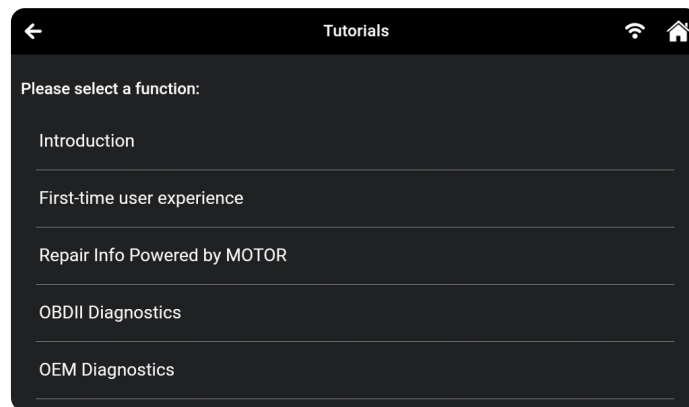

7111 INTRODUCTION

This tutorial offers a video presentation introducing the tablet, providing insights into its features and offering a teaser for the latest functionality.

1. From the Tutorials screen, tap **Introduction**.
 - The 7111 Introduction dialog displays.

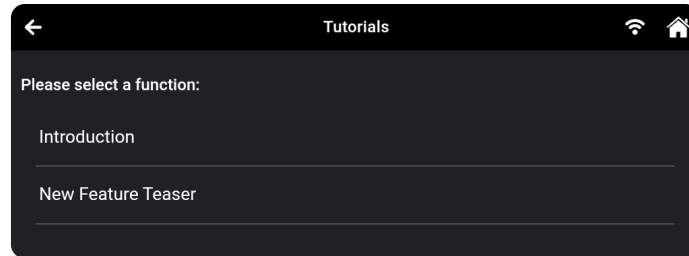

2. Tap the **Introduction** or **New Feature Teaser** as desired.
 - The screen displays a video with instructions about this feature.



FIRST TIME USER EXPERIENCE

When you turn on your tablet for the first time, this feature will automatically emerge to help by offering instructions on the tablet's various features and demonstrating efficient utilization of its components.

1. From the Tutorials screen, tap **First-time user experience**.
 - The First-time user experience screen displays.

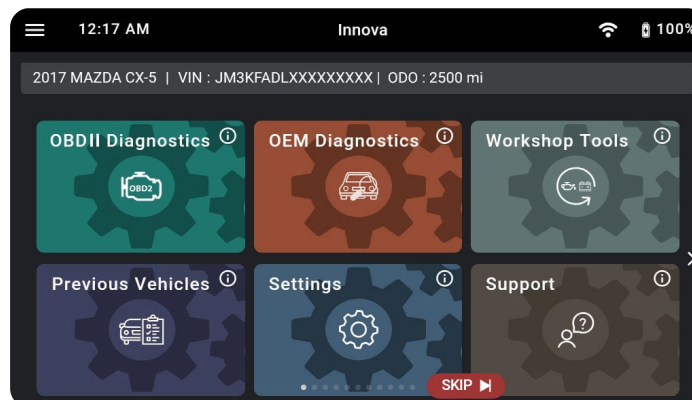

- If you wish to skip the tutorial, use the "**SKIP**" button located at the bottom of the initial tutorial screen. This allows you to go directly to the main application interface.
2. The Tutorial will guide you on how to use the different functions of the tablet. For an overview and detailed insight into each function, swipe sideways to view each step of the tutorial.

- Once you've completed the tutorial and feel confident in using the tablet, press the **"FINISH"** button on the last screen of the tutorial. This will conclude the tutorial session.

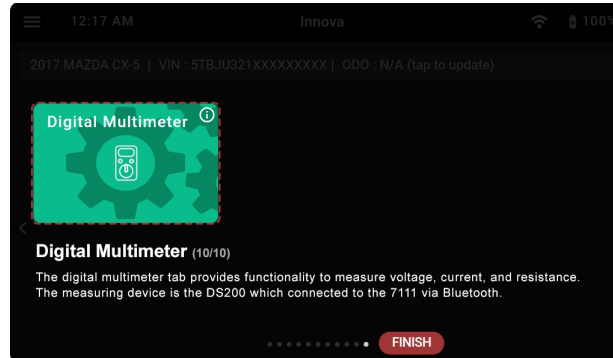

REPAIR INFO POWERED BY MOTOR

This tutorial provides instructional videos for how to use the MOTOR data on the tablet.

1. From the Tutorials screen, tap **Repair Info Powered by MOTOR**.
 - The Tutorial for **Repair Info Powered by MOTOR** screen displays.

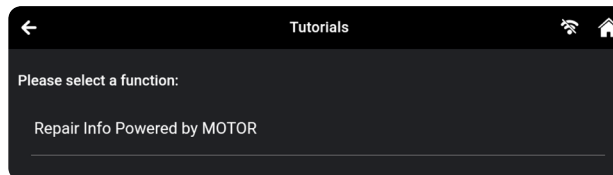

2. Select the function for which you wish to view the tutorial as desired.
 - The screen displays a video with instructions about the selected function.

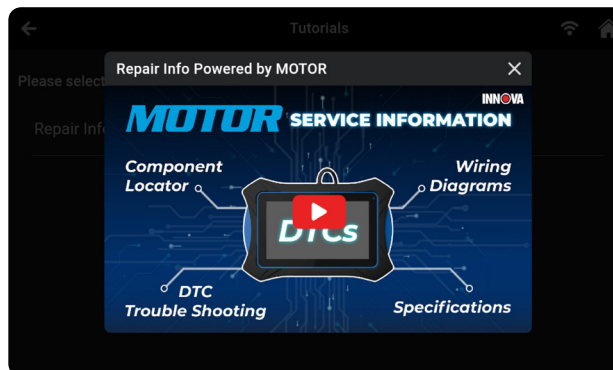

OBD II DIAGNOSTICS

This tutorial provides instructional videos for the tablet, covering all 10 OBD II modes.

1. From the Tutorials screen, tap **OBD II Diagnostics**.
 - The Tutorial for OBD II Diagnostics screen displays.

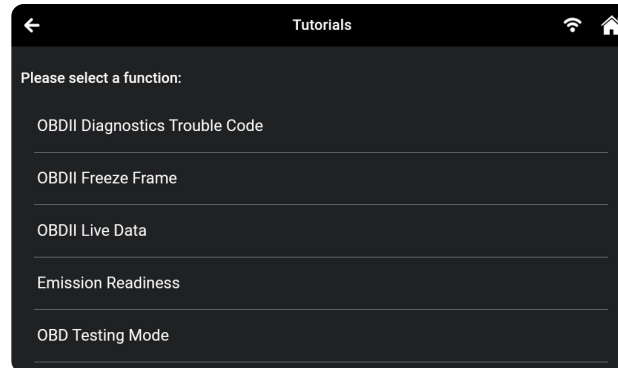

2. Select the function for which you wish to view the tutorial as desired.
 - The screen displays a video with instructions about the selected function.



OEM DIAGNOSTICS

This tutorial includes instructional videos for the tablet focusing on OEM Diagnostics.

1. From the Tutorials screen, tap **OEM Diagnostics**.
 - The Tutorial for OEM Diagnostics screen displays.

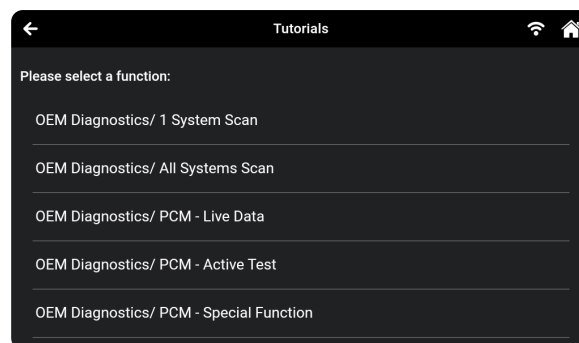

2. Select the function for which you wish to view the tutorial as desired.
 - The screen displays a video with instructions about the selected function.



WORKSHOP TOOLS

This tutorial provides guidance on performing service functions within Workshop Tools.

1. From the Tutorials screen, tap **Workshop Tools**.
 - The Tutorial for Workshop Tools screen displays.

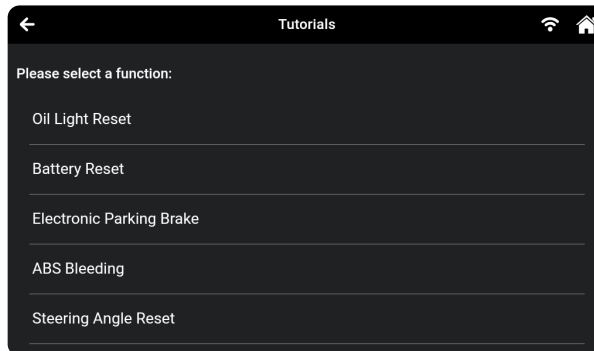

2. Select the function for which you wish to view the tutorial as desired.
 - The screen showcases a tutorial video demonstrating the steps to execute the selected function.



SETTINGS

This tutorial provides instructions on settings tablet preferences, reporting issues, updating firmware, and registering accounts.

1. From the Tutorials screen, tap **Settings**.
 - The Tutorial for Settings screen displays.

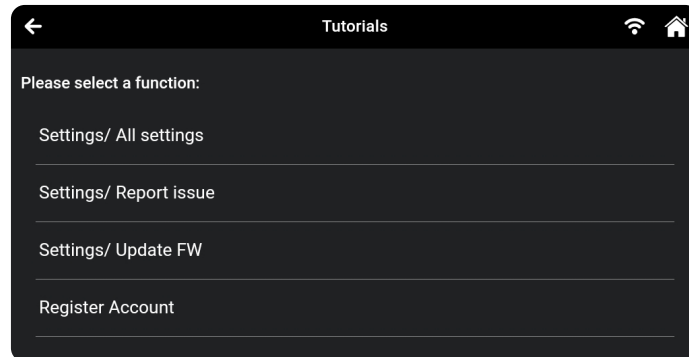

2. Select the function for which you wish to view the tutorial as desired.
 - The screen showcases a tutorial video demonstrating the steps to execute the selected function.



PREVIOUS VEHICLES/SCAN HISTORY

This tutorial provides guidance on viewing reports for scanned vehicles and sending reports via email.

1. From the Tutorials screen, tap **Previous Vehicles/Scan History**.

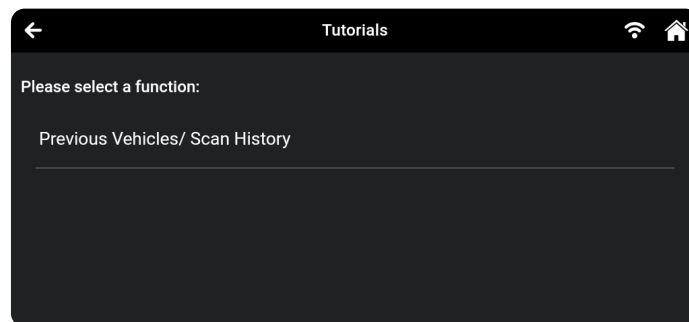

- The Tutorial for Settings screen displays.

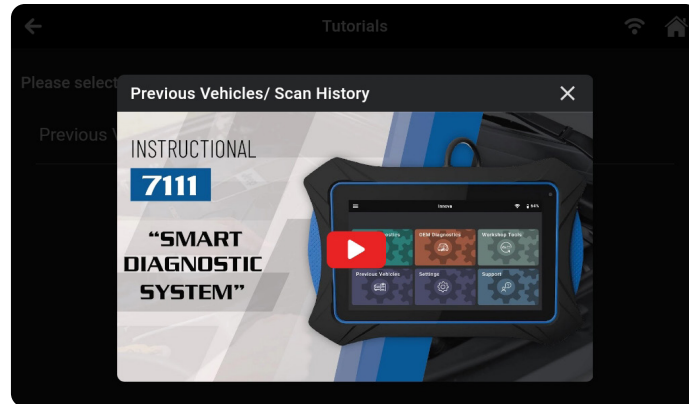

2. Tap the **Previous Vehicles/Scan History**.

- The screen showcases a tutorial video demonstrating the steps to execute this function.

TECHNICAL SUPPORT

The Innova Electronics technical team is based in Irvine, California and is always ready to help!

To connect with Technical Support:

1. From the Home screen, tap **SUPPORT**. (You can also access it from the ☰ Main Menu by tapping ² **Support**.)
 - The Support selection dialog displays.
2. Tap the **Technical Support** button.
 - The Technical Support dialog displays.
3. Tap **Email Support**.
 - The Support by Email dialog displays.

- The **Email** field shows the most recently entered email address for the tablet. If no address was previously entered, the Email field shows an empty text box.





NOTE: You *MUST* provide a personal email address to receive a reply from Innova Technical Support via email.

4. To enter an **Email** address for the first time:
 - Tap the **Email** text box, then enter your personal email address.
5. To change an existing **Email** address:
 - Tap **Change**. The current Email address displays in an editable text box.
6. Tap the **Send** button to send your email to Innova Technical Support.
 - To cancel your message without sending, tap **Cancel** to return to the Technical Support dialog.
 - A “confirmation” message displays. Tap **Close** to close the message.

DEMO MODE

The Demo Mode offers both convenience and clarity. It provides a glimpse into the tablet’s capabilities, features, and functions. This allows you to explore its potential firsthand without the need to connect to a vehicle.

1. From the Home screen, tap **SUPPORT**. (You can also access it from the  Main Menu by tapping  **Support**.)
 - The Support selection dialog displays.
2. Tap the **Demo Mode** button.
 - The Demo Mode screen displays.

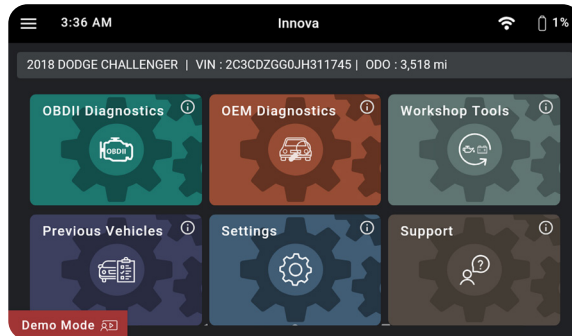

- The screen displays the tablet’s available functions, and includes the vehicle information, VIN number, and Odometer value for a simulated vehicle, as if scanning a real vehicle.
3. Select the desired function on the “Demo Mode” screen, such as **OBD II Diagnostics**.
 - The OBD II Diagnostic screen displays.

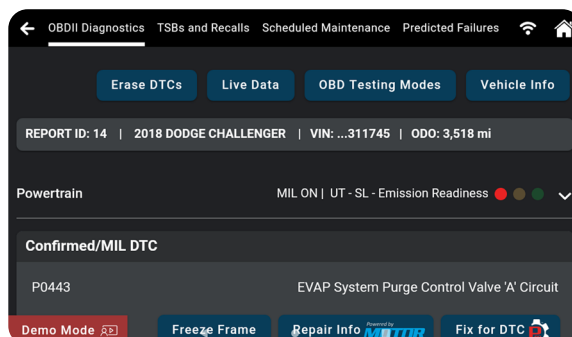

- A list of information for the system displays after scanning, such as Live Data, Erase DTCs, OBD Testing Modes, etc. You can select these functions to observe how the tablet performs in real vehicles.
4. To exit Demo Mode, tap the **Demo Mode** button displayed in the lower left corner of the screen at any time.
 - A pop-up appears to confirm your selection.

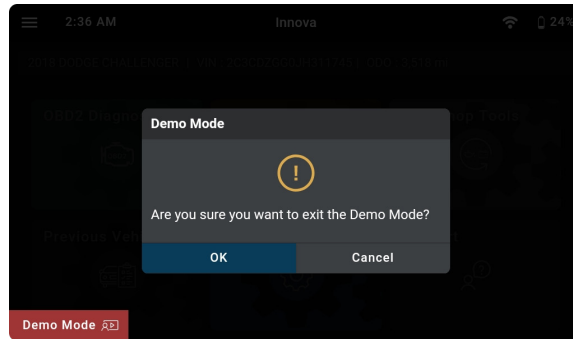

5. Tap **OK** to finish the process and return to the Support page, or tap **Cancel** to continue using Demo Mode.

DIGITAL MULTIMETER

The **Digital Multimeter** tab offers features for measuring voltage, current, and resistance. The optional **DS200** serves as the measuring device, connected to the tablet via Bluetooth. The tablet's integrated digital multimeter surpasses the capabilities of an average device.



INTRODUCTION

1. From the Home screen, tap **Digital Multimeter**.
2. Tap the **Connect** button to initiate the function.
3. The display provides two channels, each with the ability to perform separate measurements simultaneously. These independent channels can be discreetly hidden when not in use, enhancing the overall user interface with a streamlined and user-friendly design.

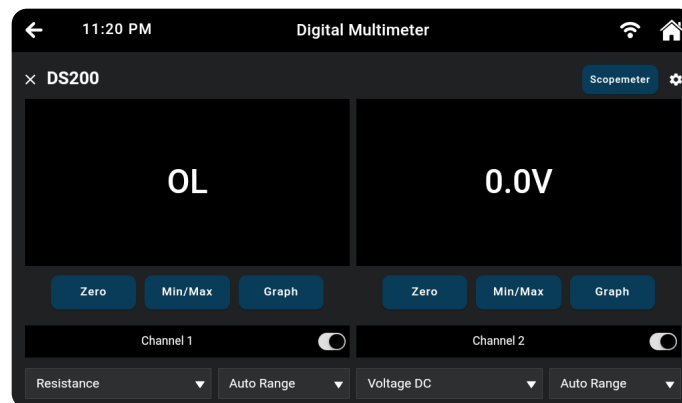
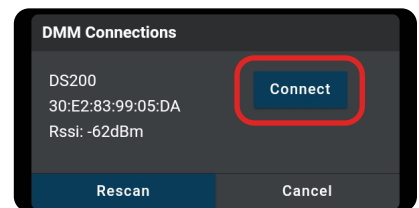

4. Each channel offers a range of measurement options in the Meter Measurement Menu, including Current, Voltage, Resistance, AMP Clamp Meter Mode, Diode Drop, and Continuity. It's important to note that different measurements necessitate specific setups.

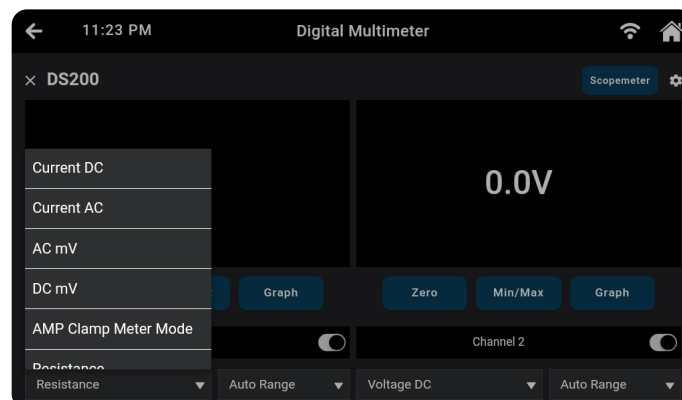

- In terms of measurement range settings, users can either manually choose their desired range or opt for the **Auto Range** feature. This simplifies configuration adjustments and improves accuracy.

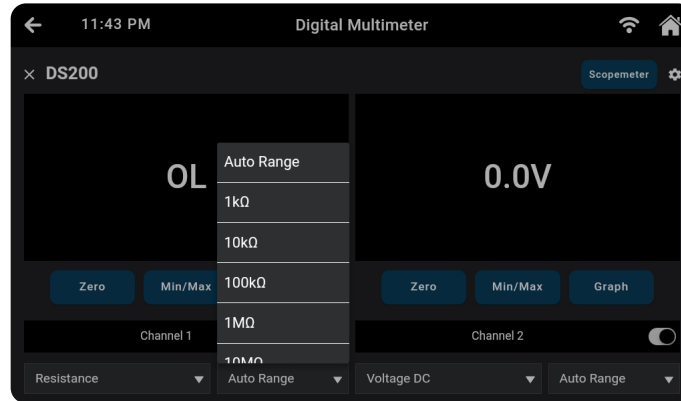

- The "Zero" function facilitates easy calibration of the current reading to zero (0), serving as a reference point for all subsequent measurements and eliminating offset values.

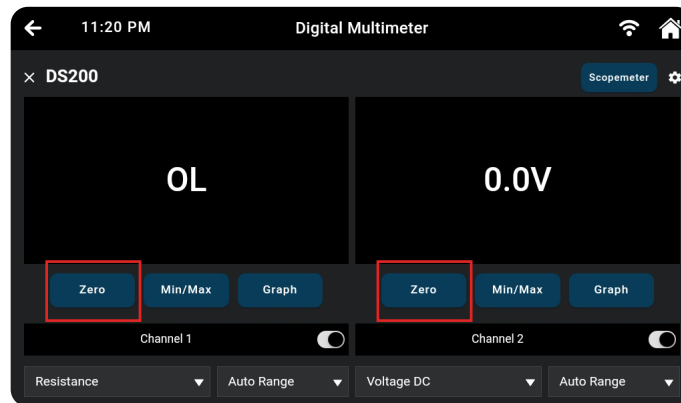

- The Min/Max function automatically logs the highest and lowest values during the measurement period, eliminating the need for manual tracking.

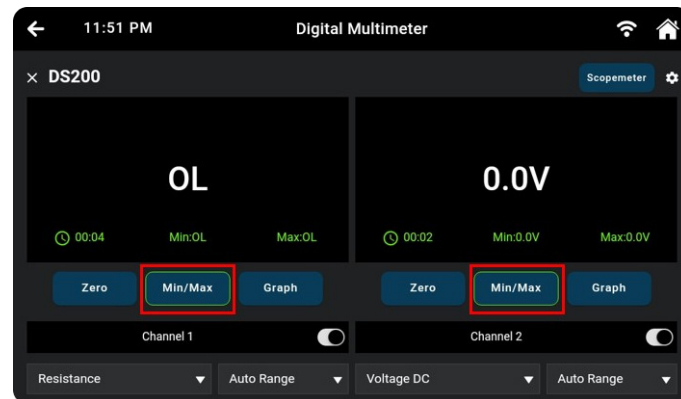

- The Graph function lets you visually represent measured values over time, providing a graphical representation that is particularly advantageous for capturing waveforms.

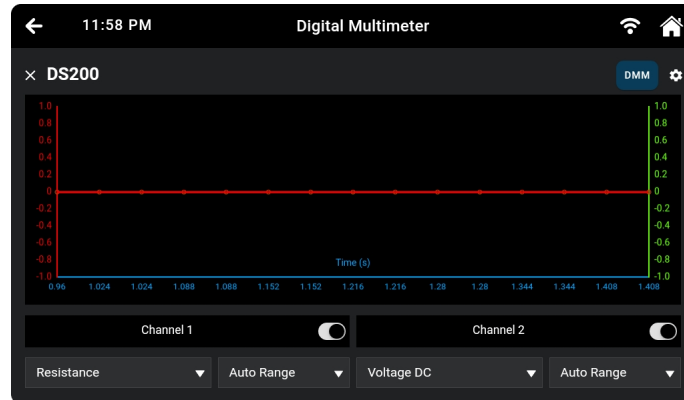

- Similarly, the Scopemeter feature merges data from both channels into a cohesive graph, effectively illustrating the interaction between the two parameters.

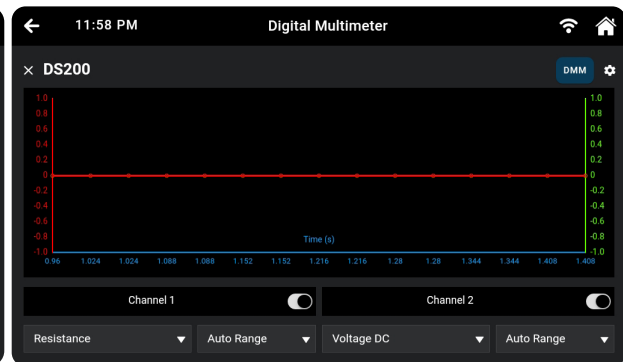
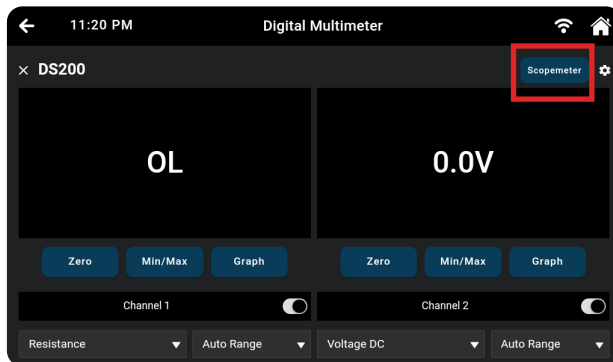

LIVE DATA SPLIT SCREEN MODE

An exceptional aspect of the Innova tablet and DS200 integration is its ability to display Live Data and DMM values on a single display view. This time saving feature allows users to simultaneously use the digital multimeter alongside real-time vehicle data.

- Connect to the vehicle by following the steps for PERFORMING A SCAN - OBD II Diagnostics. [\[See page 17\]](#)
- While linked to the vehicle, start the engine.
- Tap the **Live Data** button at the top of the OBD II Diagnostic results page to place the tablet in Live Data mode.
 - A progress message displays while the vehicle is scanned, and Live Data mode is activated.
 - Tap **Cancel** to exit the procedure.
- The results screen displays all of the vehicle's available PIDs with reported values.
- Tap the **DMM** button. The screen switches to the Live Data Split Screen mode.
- Measure, compare, and analyze values instantly as desired.

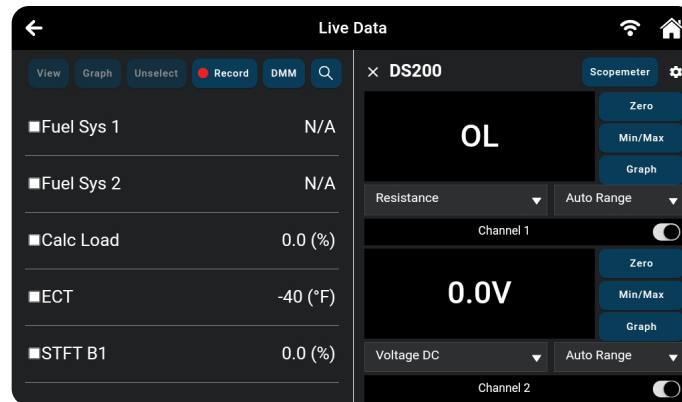

DMM SETTINGS

The DMM settings enable you to configure the Hibernation Mode, reboot the meter, access Version Information, set the Sample Window and Speed, and view the Device Name.

1. Tap the **Settings** icon to access the DMM Settings.
2. The tablet displays the DMM's settings screen.
 - **Hibernation Mode** – Toggle switch places the DS200 in hibernation mode and deactivates the device's Bluetooth® radio signal.
 - **Reboot** – Toggle switch restarts the meter and automatically returns it to the scanning screen.
 - **Version Information** – Provides details about the tablet's Software version and the DS200's Bundled Firmware Version.
 - **Sample Window and Speed** – Lets you set and determine the tablet's sample rate and speed to display readings.
 - **Device Name** – Allows you to customize your DMM device name – the default name is DS200. Simply tap **Edit** to rename your device.
3. To leave the DMM Settings, tap the **Back** button to return to the Digital Multimeter screen.

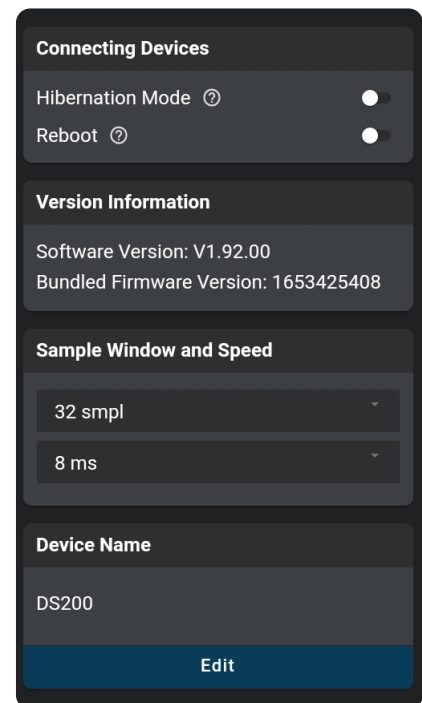
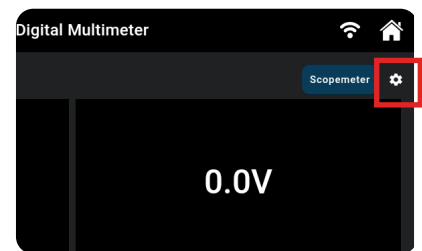

TROUBLESHOOTING & FAQ

TROUBLESHOOTING

1. When you cannot update the Innova 7111 Tablet

- **Criteria to Update:** Before you select **Check for Updates** to update your Innova 7111 Tablet ensure that you met the following criteria.
 - Make sure that your tablet is up to date, and that your software version is an older version.
 - Your tablet is connected to a stable Wi-Fi connection.
 - Your tablet is above 50% battery. If your battery is under 50% then the tablet will not allow you to update your device.
 - There may be multiple updates needed for your device, make sure to navigate back to your Settings and tap **Check for Updates** again until it says that there are no further updates for your device. Failing to do so will lead to unpredictable issues for your tablet such as VCI failing to be found, screen issues, or flickering.
- **Troubleshooting:** After you have met the criteria, follow the steps below to update your tablet.
 - Power on your tablet.
 - At the Home screen, select **Settings**.
 - Scroll down to the **About** interface.
 - Select **Check for Updates** to begin updating your device.
 - During the update process, a pop-up message appears requesting permission to write new data to the tablet. You must select **Allow** for the update to complete successfully; selecting **Deny** will cause the update to fail.
- **If you are in another country and are trying to update your Innova 7111 Tablet, follow these steps:**
 - Power on your tablet.
 - At the Home screen, select **Settings**.
 - Scroll down to the Time zone field. Select your Time zone.
 - Scroll down to the **About** interface.
 - Select **Check for Updates** to begin updating your device.

2. Battery Troubleshooting Guide

- **Purpose:** The purpose of this troubleshooting is to address the following situations:
 - If you've just purchased the product and it won't turn on.
 - If you've been trying to charge it and it appears to be dead.
 - **Troubleshooting:** Sometimes it will take a maximum of up to 4 hours before the charging symbol appears on your Innova 7111 device.
-

- Plug your charger into your Innova 7111 Tablet to begin charging.
- Leave your device charging for at least 4 hours before use or overnight for best results.
- The tablet will only charge when plugged into an outlet, using the 5V DC 2A charger that is provided.

■ **The most common issues with charging the battery:**

- **You plug the charger into the device but the charging symbol does not appear.** In this case, the battery is still being charged but there is a delay before the battery symbol appears again. We recommend waiting up to four hours and the charging symbol should appear on your device.
- **You plug the charger into the device but the device will still not turn on.** In this case, we recommend leaving your device to charge overnight before use.
- **You attempt to charge the tablet via USB port but it does not turn on.** In this case, your tablet will only be charged when connected to an outlet using the 5V DC 2A charger that is provided. Your tablet will not charge when connected via a USB port.

3. Troubleshooting Vehicle Communication Interface (VCI) Connector Errors

■ **Possible Issues:** If your INNOVA 7111 Tablet is experiencing one or more of the issues listed below, follow the troubleshooting steps listed in this document:

- The tablet crashed and is now stuck on a rebooting cycle.
- The tablet displays a “VCI not detected” error message.
- After updating the table’s firmware/software, the Home screen experiences glitches with the OBD II Diagnostics/ OEM Diagnostic/ Workshop selection tabs.
- The OBD II Diagnostics/ OEM Diagnostics/ Workshop selection tabs are grayed out while the VCI is connected to the tablet.
- The Date and Time are not correct on your 7111 Tablet, in which case you need to change the date and time to the current time and save the adjustment. **Reminder:** Your battery needs to be above 50% to complete an update.

■ **Troubleshooting Steps:**

- If you are plugged into the DLC, disconnect the tablet from the vehicle’s DLC.
- Remove the VCI from the tablet.
- Turn Off the tablet.
- Check the VCI’s Connector and Pogo Pins. Dirty connectors may cause VCI detection and connection issues. To clean the connectors and pogo pins, use alcohol wipes or a wire brush to remove any dirt and grime that might have collected during use.
- Reconnect and Power On the tablet.
- Successful Connection Confirmation.

FAQ

? What can the tablet do for my vehicle?

- ✓ Please check the coverage on our Coverage Checker website. <https://pro.repairsolutions.com/Support/CoverageChecker>

? What should I do if a communication error occurs?

- ✓ Please follow these steps to troubleshoot the issue:
 1. Check if the tablet DLC cable is securely plugged into the vehicle's DLC port.
 2. Turn the ignition off, then turn it on again after 10 seconds. DO NOT start the engine and proceed with the operation.
 3. Check if the vehicle's control module is defective.

? Can the tablet be used in other countries?

- ✓ The tablet only supports diagnostics for vehicles sold in the U.S. and Canada. For vehicles manufactured in other countries, the tablet only supports the Malfunction Indicator Light function.

? Can the tablet operate without internet connectivity?

- ✓ Yes, the tablet still functions normally without needing an internet connection.

? How to connect with the RSPRO® app on mobile device?

- ✓ The tablet currently cannot connect to the RSPRO® app on mobile devices. Instead, it utilizes the RSPRO® app integrated into its own software.

? The tablet displays a message "Could not connect to server".

- ✓ The server might be undergoing maintenance. Please try again later.

? Can I use the tablet with a wireless connection?

- ✓ Yes. The Innova 7111 Tablet supports two operating modes:
 - **USB mode:** In this mode, the VCI connector is attached to the tablet, eliminating the need for a Bluetooth connection.
 - **BLE mode:** In this mode, the VCI connector allows mobility and flexibility around the vehicle by detaching the tablet from the DLC cable and wirelessly connecting via Bluetooth.

WARRANTY & CUSTOMER SERVICE

LIMITED WARRANTY

The Manufacturer warrants to the original purchaser that this unit is free of defects in materials and workmanship under normal use and maintenance for a period of one (1) year from the date of original purchase.

If the unit fails within the one (1) year period, it will be repaired or replaced, at the Manufacturer's option, at no charge, when returned prepaid to the Service Center with Proof of Purchase. The sales receipt may be used for this purpose. Installation labor is not covered under this warranty. All replacement parts, whether new or remanufactured, assume as their warranty period only the remaining time of this warranty.

This warranty does not apply to damage caused by improper use, accident, abuse, improper voltage, service, fire, flood, lightning, or other acts of God, or if the product was altered or repaired by anyone other than the Manufacturer's Service Center.

The Manufacturer, under no circumstances shall be liable for any consequential damages for breach of any written warranty of this unit. This warranty gives you specific legal rights, and you may also have rights, which vary from state to state. This manual is copyrighted with all rights reserved. No portion of this document may be copied or reproduced by any means without the express written permission of the Manufacturer. **THIS WARRANTY IS NOT TRANSFERABLE.** For service, send via U.P.S. (if possible) prepaid to Manufacturer. Allow 3-4 weeks for service/repair.

CUSTOMER SERVICE

Our ASE Certified technical staff is here to help if you have any questions or require service. For information on UPDATES and OPTIONAL ACCESSORIES, please contact your local store, distributor or Innova's Service Center.

USA & Canada: (800) 544-4124
Monday through Friday: 6:00 AM to 6:00 PM Pacific Time

All others: (714) 241-6802
Monday through Friday: 6:00 AM to 6:00 PM Pacific Time

Web: <https://pro.repairsolutions.com>



TECHNICAL ASSISTANCE
1 800 544 4124
HABLAMOS ESPAÑOL • SERVICE IN THE USA
ASE CERTIFIED TECHNICIANS

INNOVA.COM

INNOVA[®]
Innova Electronics Corp.
17352 Von Karman Ave.
Irvine, CA 92614

Copyright © 2025 IEC. All Rights Reserved.
MRP# 97-2191

